

IMPEDANCE MEASUREMENTS ON A TEST BENCH MODEL
OF THE ILC CRAB CAVITY

P. Gouket, C. Beard, P. McIntosh, ASTeC/Cockcroft Institute, STFC, Daresbury WA4 4AD,
UK

G. Burt, A. Dexter, Cockcroft Institute, Lancaster University, Lancaster, LA1 4YR, UK
N. Chanlek, R. M. Jones, Manchester University, Manchester, UK

IMPEDANCE MEASUREMENTS ON A TEST BENCH MODEL OF THE ILC CRAB CAVITY

P. Goudket, C. Beard, P. McIntosh, ASTeC/Cockcroft Institute, STFC, Daresbury WA4 4AD, UK
G. Burt, A. Dexter, Cockcroft Institute, Lancaster University, Lancaster, LA1 4YR, UK
N. Chanlek, R. M. Jones, Manchester University, Manchester, UK

Abstract

In order to verify detailed impedance simulations, the resonant modes in an aluminium model of the ILC crab cavity were investigated using a bead-pulling technique as well as a stretched-wire frequency domain measurement. The combination of these techniques allow for a comprehensive study of the modes of interest. For the wire measurement, a transverse alignment system was fabricated and RF components were carefully designed to minimize any potential impedance mismatches. The measurements are compared with direct simulations of the stretched-wire experiments using numerical electromagnetic field codes. High impedance modes of particular relevance to the ILC crab cavity are identified and characterized.

EXPERIMENTAL APPARATUS

The baseline ILC design calls for two superconducting nine-cell 3.9GHz dipole mode cavities [1] in order to rotate the bunches at the interaction point and preserve luminosity. A numerical study carried out on the cavity identified a number of modes that have significant loss factors [2] and therefore would require significant damping. In order to verify the impedances calculated by the numerical simulations, a modular aluminium model of the cavity was constructed.

The model is composed of modular pairs of half-cells, connected at the equator. These can be arranged to form a cavity having anything from one to thirteen cells. The cell profiles are based on the C15 shape of the CKM 3.9GHz cavity [3].

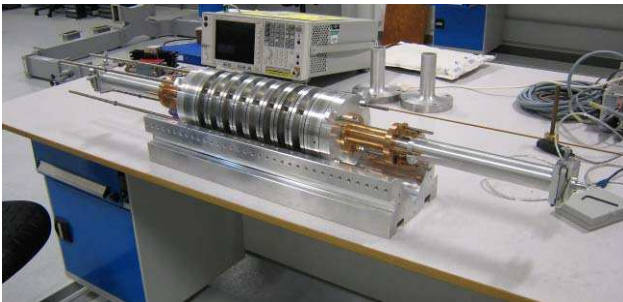

Figure 1: Picture of the experimental model.

The stretched-wire measurements were taken using matching sections at both ends of the cavity beam-pipe in order to minimise reflections and mode conversion. The matching sections were comprised of a tapered cone, and a quarter-wave transformer which allowed a reasonably

good pass-band. It was possible to use different quarter-wave transformers to study different frequency ranges.

The wire position was controllable in the X and Y directions on both ends of the cone, which allowed measurements at various offsets and allowed control of the skew. The translation plates as well as tensioning mechanisms are shown in Figure 2.

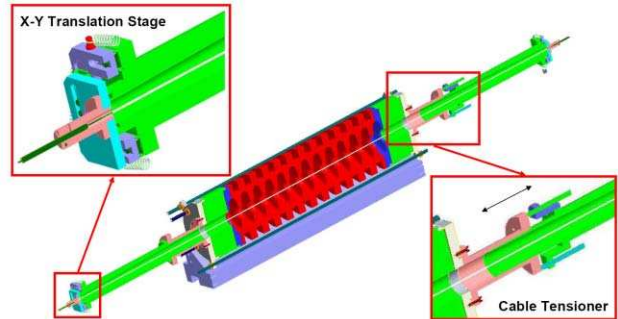

Figure 2: Schematic of the stretched-wire apparatus.

STRETCHED-WIRE THEORY

The field pattern generated by a current passing through a wire in a coaxial structure is a TM mode that can be equated to the wake-fields left by a bunch passing through a structure.

From simple transmission line theory, it is possible to derive a relationship between the coupling impedance of the device under test (DUT) and the ratio of transmission parameters, S_{21} , of the DUT and a reference vessel [4]. The ratio can be expressed as follows:

$$\frac{S_{21,DUT}}{S_{21,ref}} = \frac{\exp(i\theta)}{\cos(\zeta\theta) + \frac{i}{2} \left(\zeta + \frac{1}{\zeta} \right) \sin(\zeta\theta)} \quad (1)$$

where θ is the TEM modes wavenumber multiplied by the length of the DUT and

$$\zeta = \sqrt{1 - \frac{iZ_{||}}{\theta Z_0}} \quad (2)$$

Hence if we can measure S_{21} of a DUT and a reference vessel of known characteristic impedance Z_0 we can solve equation (1) to obtain the longitudinal coupling impedance $Z_{||}$.

It is often convenient to use the logarithm of equation (1) as an approximation.

$$\ln\left(\frac{S_{21,DUT}}{S_{21,Ref}}\right) = -i(\zeta - \theta) + \ln\left[\frac{4\zeta}{(\zeta+1)^2 - e^{-i\theta}(\zeta-1)^2}\right] \quad (3)$$

Performing a Taylor expansion of this gives the 1st order solution known as the log formula:

$$\ln\left(\frac{S_{21,DUT}}{S_{21,Ref}}\right) = -\frac{Z_{\parallel}}{2Z_0} \quad (4)$$

this solution is valid if the coupling impedance is of similar magnitude to the impedance of the reference vessel.

If the modes are sufficiently separated in frequency (a few bandwidths) then the coupling impedance can be integrated along the mode's bandwidth to calculate the loss factor of each mode using;

$$k_{loss} = 2 \int_{\text{mode}} \text{Re}\{Z_{\parallel}\} df = \frac{V^2}{4U} = \frac{r^2 \omega R}{2 Q} \quad (5)$$

where V is the longitudinal voltage of the cavity, U is the cavity's stored energy, ω is the angular frequency, r is the offset of the wire from the cavities electrical centre and R/Q is the geometric shunt impedance. In addition the coupling impedance can be derived for a single mode from a simple L-R-C resonant circuit [5]

$$Z_{\parallel} = \frac{Q}{\pi\omega_0} \frac{k_{loss}}{1 + Q^2 \left(\frac{\omega}{\omega_0} - \frac{\omega_0}{\omega}\right)^2} \quad (6)$$

If we perform a best fit to this equation from the measured impedance we can find the loss factor, resonant frequency, ω_0 , and loaded Q factor of the mode.

STRETCHED-WIRE MEASUREMENTS

Methodology and observations

Using the equations described above, one can therefore calculate the loss factors of modes from simple S_{21} measurements taken with a network analyser. Repeated measurements were taken of the cavity which was set-up as a nine-cell structure. The reference measurement was defined to be the measurement taken with the wire on-axis – this position being found by adjusting the translation micrometers until the dipole mode peaks are minimised (first adjustment on the 3.9GHz first dipole mode; higher order modes provided a finer sensitivity in

order to improve alignment and remove wire skew). This allows the singling out of dipole and higher order modes. The wire may however perturb some of the monopole modes, due to their strong coupling to the wire, causing their resonant frequency to shift as the wire moves off axis. This can cause errors in the impedance calculation as the ratio of the transmission between the on and off axis cases are no longer unity. Care should be taken to ensure that there are no monopole modes around the frequencies of interest.

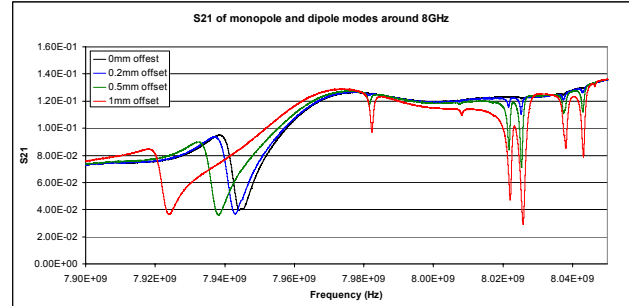

Figure 3: S_{21} of monopole and dipole modes at various wire offsets.

Figure 3 shows an example of various measurements taken at different wire offsets of the region around 8GHz. A monopole mode around 7.94GHz is visible even with an on-axis wire and is strongly affected by the wire offset. The resonances at higher frequencies are dipole modes; this is apparent because of the relationship between offset and the increase in reflected power.

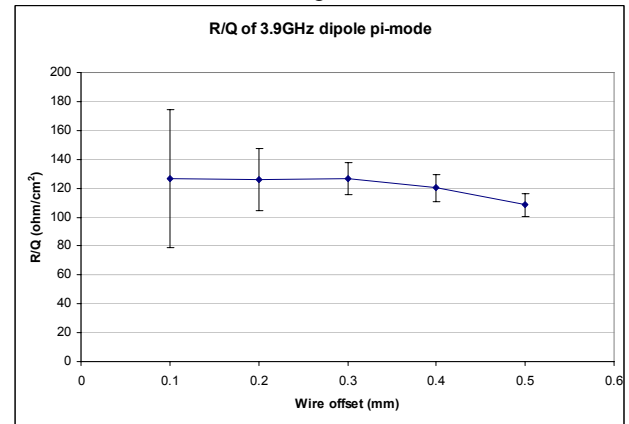

Figure 4: Measured R/Q of the first dipole mode at various wire offsets.

Figure 4 shows that the accuracy of the measurement is affected by both the proximity of the wire to the axis and the perturbation the wire will cause on the mode. The large error-bars at low values of wire displacement are caused by the inherent uncertainty about the exact wire position in relation to the actual electrical centre of the cavity. At higher values of offset, the wire perturbs the modes to a greater extent and affects the result by shifting the frequency of the mode as well as lowering the R/Q. The figure suggests that an optimal offset of about 0.3mm should be used for future measurements.

Analysis

The coupling impedance was calculated, using the measured transmission from the cavity, using both the log formula and the exact formula. It was found that the two methods were in perfect agreement for all the dipole modes identified in the measurement.

Figure 5 shows an example of impedances calculated from the S_{21} measurements shown in Figure 3.

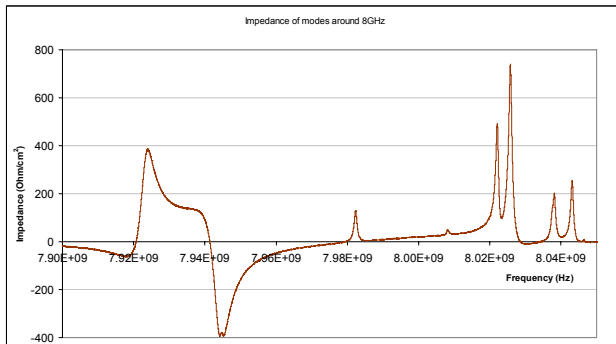

Figure 5: Measured impedances at 1mm wire offset of modes around 8GHz.

The modes from 7.98GHz onwards are higher order dipole modes that resonate in the cavity in that frequency range. They are quite close to monopole modes that are visible around 7.94GHz. The values calculated in that region are unphysical and are caused by the movement of the monopole modes resonant frequencies. The modes at 8.02 GHz are the π and $8\pi/9$ modes of the 5th dipole passband. Numerical simulations using the finite difference code, MAFIA [6], have previously shown that these modes are expected to have high loss factors [2]. The largest of these peaks was calculated to have an R/Q of $11.6 \Omega/\text{cm}^2$ which is in excellent agreement with the mean R/Q measured at a wire offset of 1mm for this mode.

The modes with the highest R/Qs were found to be the operating mode and its opposite polarisation at 3.9 GHz. These modes were measured to have an R/Q of $127 \Omega/\text{cm}^2$, which is lower than value of $154 \Omega/\text{cm}^2$ calculated using MAFIA. The reason for the reduction in R/Q is believed to be the reduced field flatness in the aluminium model, which is un-tuned.

Simulations suggest that the modes most likely to have high loss factors are the Same Order Mode (SOM), which is the other polarisation of the operating mode, as well as modes at 7.08, 7.14, 7.18, 7.39, 8.04, 10.03, 10.05, 12.98, 13.0 and 13.01GHz. The SOM is not distinguishable from the operating mode in this model because the cells are not polarised to lift the degeneracy. The modes at 7.08, 7.14 and 7.18GHz are in a region rife with monopole modes, which means that no accurate measurement of their R/Q was possible. All of the other modes listed above were however measurable and had values very close to those predicted by simulations. No high impedance dipole mode that had not been predicted by the simulations was found in the cavity.

CONCLUSIONS

The stretched-wire system was used to measure the dipole mode impedances in a 9-cell cavity. These measurements were accurate and repeatable to within less than 10% at appropriate offset levels. The calculated values of impedances and R/Q match the simulated values to within an acceptable degree. Every high impedance dipole mode found through the measurement had been predicted by the simulations.

ACKNOWLEDGEMENTS

The authors would like to thank Prof. R. Carter and Dr. F. Caspers for their invaluable advice and suggestions in preparation for these measurements.

This work was supported by PPARC and the EC under the FP6 "Research Infrastructure Action - Structuring the European Research Area" EUROTeV DS Project Contract no.011899 RIDS.

REFERENCES

- [1] ILC-RDR, <http://www-project.slac.stanford.edu/ilc/acceldev/bea/mdelivery/rdr/>
- [2] C. Adolphsen et al. Design of the ILC Crab Cavity system, EUROTeV-Report-2007-010 Crab Cavity
- [3] M. McAshan, R. Wanzenberg, RF Design of a Transverse Mode Cavity for Kaon Separation, FERMILAB-TM-2144, May 2001.
- [4] V. G. Vaccaro, Coupling impedance measurements: an improved wire method, INFN/TC-94/023, Sezione di Napoli, November 1994.
- [5] Impedances and Wakes in High Energy Particle Accelerators, B. Zotter, S. Heifets, World Scientific, 1998.
- [6] MAFIA, CST GmbH, Germany