

# DEVELOPMENT OF A 352 MHz CELL-COUPLED DRIFT TUBE LINAC PROTOTYPE

Y. Cuvet, J. Genest, C. Völlinger, M. Vretenar, CERN, Geneva, Switzerland  
 F. Gerigk, RAL, Chilton, UK

## Abstract

At linac energies above 40 MeV, alternative structures to the conventional Drift Tube Linac can be used to increase efficiency and to simplify construction and alignment. In the frame of the R&D activities for the CERN SPL and Linac4, a prototype of Cell-Coupled Drift Tube Linac (CCDTL) at 352 MHz has been designed and built. This particular CCDTL concept is intended to cover the energy range from 40 to 90 MeV and consists of modules of ~5 m length made of 3-gap DTL tanks linked by coupling cells. The focusing quadrupoles are placed between tanks, and are aligned independently from the RF structure.

The CCDTL prototype consists of two half tanks connected by a coupling cell and requires an RF power of 120 kW to achieve the design gradient. RF tests will be made at low and high power, the latter up to a 20% duty cycle. This paper introduces the main features of this CCDTL design and describes the RF and mechanical design of the prototype.

## THE CERN CCDTL

The new Linac4 presently under study at CERN will accelerate an  $H^-$  beam to a kinetic energy of 160 MeV, making use of 352 MHz RF equipment (klystrons, waveguides and circulators) recuperated from the LEP machine [1]. This frequency is almost ideal for an  $H^-$  linear accelerator, offering a good compromise between size, maximum gradient, efficiency and focalization in the RFQ.

After the RFQ and a 3 MeV chopper line, the present Linac4 layout foresees an Alvarez-type Drift Tube Linac (DTL). The first DTL tank will be equipped with Permanent Magnet Quadrupoles, while the other tanks will have conventional electromagnets. The DTL structure is expensive to build because of its large dimensions and because of the accurate alignment required for the drift tubes. Moreover, the difficult access to the drift tubes is of concern if repairs are needed. However, for a high-intensity linac where beam optics has to be smooth, the choice of the conventional Alvarez DTL is unavoidable at low energy because of its short focusing periods. When the beam energy exceeds a few tens of MeV, the focusing period can become longer, and alternative structures can be considered.

Different alternatives to the DTL have been developed, all relying on the principle of separating the focusing from the RF structure, alternating quadrupoles with short accelerating tanks. Some solutions are based on TE modes, which provide a high shunt impedance, but require relatively long tanks and unconventional beam

optics solutions, difficult to apply for high intensity operation due to the longer focusing periods. Other solutions retain the TM010 mode of the DTL, using shorter DTL tanks containing drift tubes of smaller diameter, without quadrupoles which are then placed between tanks. These structures have a lower capacitance between drift tubes than the standard DTL, but have increased losses due to a higher number of end walls, thus arriving at similar shunt impedance values to a conventional DTL. They go under the name of Separated DTL (SDTL) when the accelerating tanks are decoupled one from the other and fed by their own RF coupler, and of Cell-Coupled DTL (CCDTL) when the tanks are coupled together via coupling cells, forming a single resonator. The CCDTL was originally developed at Los Alamos at a frequency of 805 MHz [2].

The solution retained at CERN, shown in Fig. 1, is a CCDTL at the same RF frequency as the DTL, 352 MHz, and composed of 3-gap DTL-like accelerating tanks, connected by standard coupling cells [3]. Single quadrupoles are placed between tanks, giving a focusing period of  $7\beta\lambda$ . A string of 4 tanks forms a module, operating in the  $\pi/2$  mode between tanks and coupling cells, which is directly fed by a 1 MW klystron.

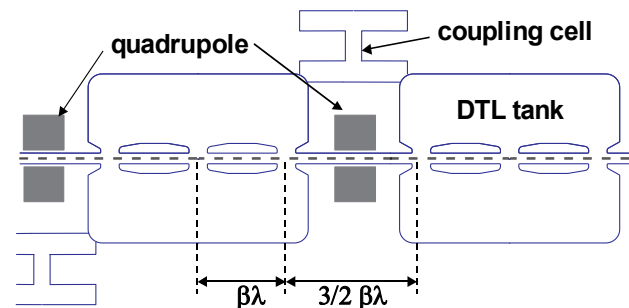

Figure 1: Outline of the CERN Cell-Coupled DTL.

The quadrupoles outside of the tanks can be easily accessed, aligned and cooled. Machining and plating of the relatively small CCDTL tanks requires a smaller and less expensive infrastructure than needed for a DTL. The alignment of the drift tubes is much less critical than in the DTL, the tolerances required for the alignment of an RF gap at this energy being between 5 and 10 times less stringent than for the alignment of the quadrupole. The module is directly fed by a klystron, clearly defining the tank phases and amplitudes. Finally, a CCDTL allows for a continuous focusing lattice, without the DTL intertank spacings, thus reducing the risk of beam mismatch.

Fig. 2 compares the computed shunt impedance of this CCDTL design with a CCDTL design with 2-gap tanks and with two standard DTL designs. In the energy range

between 40 and 80 MeV the 3-gap CCDTL presents a shunt impedance slightly higher than the DTL.

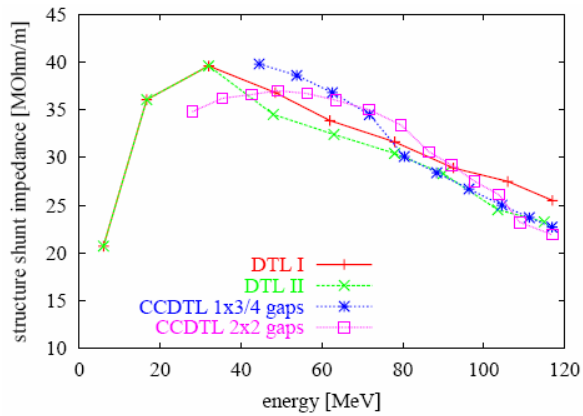

Figure 2: Comparison of shunt impedances for two CCDTL and two DTL designs.

The present CCDTL layout for Linac4 covers the energy range between 40 MeV and 90 MeV with 7 modules of four 3-gap cavities each, for a total length of 30 m. The RF input is from a coupler placed in one of the central tanks. The main design parameters are presented in Table 1 and a view of a CCDTL module in Fig.3.

Table 1: Parameters of the CCDTL design for Linac4

Input Energy	40	MeV
Output Energy	90	MeV
RF Frequency	352.2	MHz
Number of tanks	28	
Gradient $E_0$	3	MV/m
Lattice	FD	
Max. surface field	1.3	Kilp.
Aperture radius	14 - 16	mm
Synchronous phase	-25	deg
Length	30.1	m
Peak beam current	30	mA
Max. duty cycle	14	%

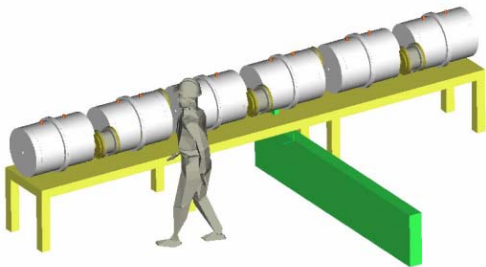

Figure 3: View of a CCDTL module.

### RF DESIGN OF THE PROTOTYPE

In order to define the mechanical engineering of this CCDTL structure and to test the cooling and the high power behavior, a CCDTL prototype has been designed and is presently in construction at the CERN workshop. It has the minimum size necessary to obtain the desired field

and loss distribution, i.e. two half tanks connected by a coupling cell, with dimensions corresponding to 40 MeV beam energy. Its basic geometry is shown in Fig. 4. The coupling between tanks and coupling cells is via a slot of 102 mm x 48 mm, providing a coupling factor of 1 %, as calculated by 3D simulation codes, sufficient for the short CCDTL modules. The estimated RF power dissipation to reach the nominal field in the prototype is 120 kW peak.

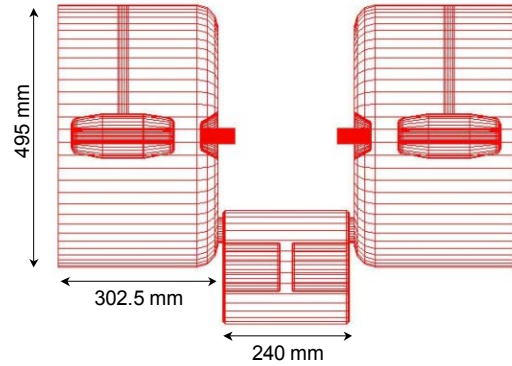

Figure 4: Geometry of the CCDTL prototype.

The CCDTL will have a single waveguide coupler for 1 MW peak power, and a maximum average power of 140 kW. A commercial waveguide window will be used, and the RF power will be coupled via an iris in one of the tanks. The dimensions of the iris have been defined using 3D RF simulations (Fig. 5), computing first of all the  $Q_0$  of the tank-waveguide assembly and then its  $Q_{ext}$  by closing the waveguide with a perfectly matched layer. The ratio of the two Q-values gives the value of the coupling  $\beta$ . The waveguide is tangential to the tank, and closed with a short-circuit at  $\lambda/4$  distance from the centre of the coupling iris. This arrangement allows precise matching of the line to the resonator, compensating for the final Q-value of the cavity and for the inaccuracies of the simulations, by changing the position of the short-circuiting plane before its brazing in the final position.

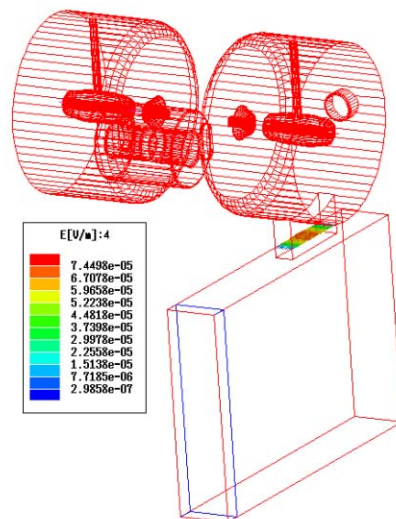

Figure 5: 3D simulation of the waveguide coupler showing the electric field on the coupling iris.

## MECHANICAL DESIGN

A preliminary analysis of the cooling requirements for 14% duty cycle indicated that the tank can be made out of copper-plated stainless steel, with cooling channels directly machined in the external part of the tank cylinder. The drift tube has to be made in copper, and cooled via the supporting stem. To ease assembly and to minimise the number of joints, half tanks are connected via a helicox joint in the tank middle plane, while the end walls are electron beam welded to the tank cylinder. The basic tank structure is shown in Figs. 6 and 7.

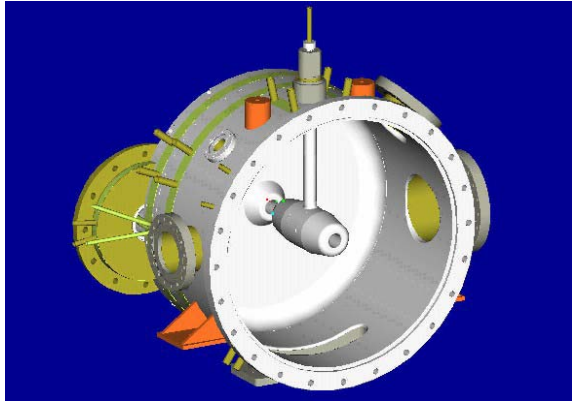

Figure 6: CCDTL prototype half tank.

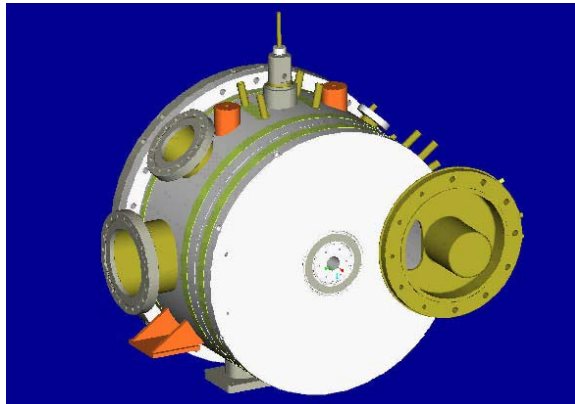

Figure 7: Rear view of the CCDTL half tank.

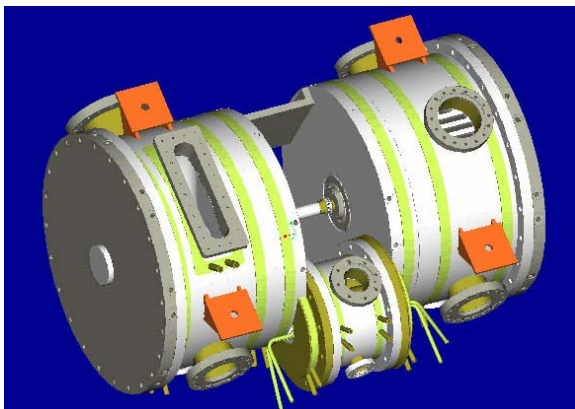

Figure 8: Assembled CCDTL prototype.

The end wall of the coupling cell is connected to the tank by electron beam welding around the coupling slot,

visible in Fig. 7. The prototype, Figure 8, is finally assembled using helicox joints. The large iris for RF coupling is clearly visible.

The thermal calculations performed on the prototype (Fig. 9) show a maximum temperature of about 100° on the pumping port grid, while 85° are reached on the cavity body. A critical spot is the coupling slot, which can go to 120° when the coupling cell is not cooled. By adding some cooling, the temperature is reduced to 52°. The temperature of the copper drift tube is limited to 30°. The calculated frequency shift due to heating is 200 kHz.

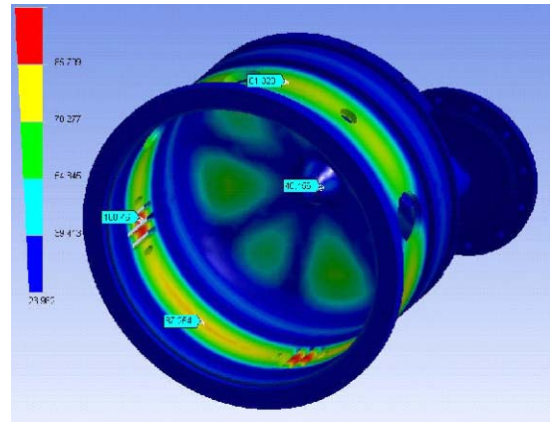

Figure 9: Thermal calculation for the CCDTL prototype.

## PRESENT STATUS AND PERSPECTIVES

Machining and welding of the prototype have been finished and the components are presently waiting for copper plating. High-power RF testing is scheduled to begin at the SM18 test stand at CERN in March 2005.

The construction of a larger size CCDTL prototype is planned in the frame of an ISTC project involving the Russian laboratories BINP (Novosibirsk) and VNIITF (Snezinsk) and CERN. The engineering of the CCDTL will be adapted to the construction technologies available in Russia, and a prototype made of two full tanks will be built and tested with RF power at CERN in 2006.

## ACKNOWLEDGEMENTS

We acknowledge the support of the European Community-Research Infrastructure Activity under the FP6 “Structuring the European Research Area” programme (CARE, contract number RII3-CT-2003-506395).

## REFERENCES

- [1] R. Garoby, F. Gerigk, K. Hanke, A. Lombardi, C. Rossi, M. Vretenar, “Design of Linac4, a new Injector for the CERN Booster”, this conference.
- [2] J. Billen, F. Krawczyk, R. Wood, L. Young., “A New RF Structure for Intermediate-Velocity Particles”, Linac 94, Tsukuba.
- [3] F. Gerigk, M. Vretenar, Design Choices for the SPL normal-conducting Front-end, PS/RF Note 2002-038.