

RN 2-14032  
COPY 2 (B.K.H.H.H.)  
ACCN: 223216

**DRAL**  
Daresbury Laboratory  
Rutherford Appleton Laboratory

**RAL Report**  
RAL-94-032

# Flavour-Violating Charged Lepton Decays in a GUT- and Superstring-Inspired Standard Model

A Ilakovac and A Pilaftsis

May 1994

**Rutherford Appleton Laboratory** Chilton DIDCOT Oxfordshire OX11 0QX

**DRAL is part of the Engineering and Physical  
Sciences Research Council**

The Engineering and Physical Sciences Research Council  
does not accept any responsibility for loss or damage arising  
from the use of information contained in any of its reports or  
in any communication about its tests or investigations

# FLAVOUR-VIOLATING CHARGED LEPTON DECAYS IN A GUT- AND SUPERSTRING-INSPIRED STANDARD MODEL

A. Ilakovac<sup>a \*</sup> and A. Pilaftsis<sup>b †</sup>

<sup>a</sup> *Institut für Physik, THEP, Johannes-Gutenberg Universität, 55099 Mainz, Germany*

<sup>b</sup> *Rutherford Appleton Laboratory, Chilton, Didcot, Oxon, OX11 0QX, England*

## ABSTRACT

Analytic expressions of lepton-flavour- and lepton-number-violating decays of charged leptons are presented in the context of  $SU(2)_L \otimes U(1)_Y$  scenarios, in which their field content is inspired by grand unified theories (GUT's) or superstring models and naturally contain left-handed and/or right-handed neutral singlets. Possible constraints imposed by cosmology and low-energy data are briefly discussed. The violation of the decoupling theorem in flavour-dependent graphs due to the presence of heavy neutral leptons of Dirac or Majorana nature is emphasized. Numerical estimates are given.

---

\*On leave from Department of Physics, University of Zagreb, 41001 Zagreb, Croatia.

†E-mail address: pilaftsis@vax2.rutherford.ac.uk

# 1 Introduction

The quest for an understanding of the problem of smallness in mass or masslessness of the light known neutrinos,  $\nu_e$ ,  $\nu_\mu$ , and  $\nu_\tau$ , has relied on interesting solutions in the context of extended gauge structures of the minimal Standard Model (SM) such as grand unified theories (GUT's), *e.g.*  $SO(10)$  models [1], or superstring models with an  $E_6$  symmetry [2]. Among the various solutions, the most attractive one, known as the "see-saw" mechanism, has been conceived by the authors in [3] in  $SO(10)$  or left-right symmetric models. In these theories, right-handed neutrinos are introduced with the simultaneous inclusion of Majorana masses that violate the lepton-number ( $L$ ) by  $\Delta L = 2$  operators in the Yukawa sector. The neutrino-mass spectrum of a simple "see-saw" model with one generation of quarks and leptons consists of two massive Majorana neutrinos,  $\nu$  and  $N$ , having masses  $m_\nu \simeq m_D^2/m_M$  and  $m_N \simeq m_M$ . If the Dirac mass term  $m_D$  is of the order of a typical charged-lepton or quark mass, as dictated by GUT relations [4], and the Majorana-mass scale  $m_M$  is sufficiently large, one can then obtain a very light neutrino  $\nu$ . The general situation of an interfamily "see-saw" model with a number  $n_G$  of weak isodoublets and a number  $n_R$  of right-handed neutrinos is more involved [5] and will be discussed in Section 2.

If nature keeps to the pathway of an ultimate solution via the "see-saw" mechanism, then heavy Majorana neutrinos,  $N_i$ , may manifest themselves in  $L$ -violating processes at high-energy  $ee$  [6],  $ep$  [7], and  $pp$  colliders [8,9], in possible lepton-flavour-violating decays of the  $Z$  [10] and Higgs particles ( $H$ ) [11] or through universality-breaking effects in leptonic diagonal  $Z$ -boson decays [12]. Their existence may also influence [13,14] a number of electroweak oblique parameters given in [15,16] or specific Higgs observables considered recently [17,18]. Finally, there are many other places scanned by exhaustive combined analyses of charged-current-universality effects in leptonic  $\pi$  decays, neutral-current interactions in neutrino-nucleon scatterings,  $\tau$ -polarization asymmetries, neutrino-counting experiments at the CERN Large Electron Positron Collider (LEP), etc. [19,20], in which Majorana neutrinos could also manifest their presence.

Another possible solution of the neutrino-mass problem has been contemplated in the framework of heterotic superstring models [2,21] or certain scenarios of  $SO(10)$  models [22].

The low-energy limit of such theories extend the SM field content by adding new left-handed and right-handed neutral isosinglets. For simplicity, one can, however, assume the absence of  $\Delta L = 2$  operators in the Yukawa sector. In a simple one-generation scenario, one obtains three Weyl fermions from which one of them is completely massless to all orders of perturbation theory [22,23] and the other two are degenerate in mass and thus form a heavy Dirac neutrino which has a mass of the order of the isosinglet Dirac mass  $M$ . The Dirac mass  $M$  simply connects the right-handed and left-handed chiral singlets in the Yukawa sector. This solution is particularly preferable if the light known neutrinos turn out to be strictly massless. The model could straightforwardly be extended to  $n_G$  generations without qualitatively changing its picture regarding neutrino masses. In an  $n_G$ -generation model, one generally obtains  $n_G$  massless neutrinos and  $n_G$  heavy Dirac neutral fermions [23,24]. This minimal model is invariant under the gauge group  $SU(2)_L \otimes U(1)_Y$  and possesses many attractive features that might be summarized in [25]. For example, even if the total lepton number is conserved, the model does generally violate the separate leptonic quantum numbers and can hence account for possible  $L$ - and/or  $CP$ -violating signals at the  $Z$  peak [23] or in other high-energy processes [26].

In this paper we carefully study the three-body decays of a charged lepton,  $l$ , into other three charged leptons, which we denote hereafter as  $l'$ ,  $l_1$ , and  $\bar{l}_2$ . After detailed calculations, we find analytically that the decay amplitude of  $l \rightarrow l' l_1 \bar{l}_2$  increase quadratically with the mass of the heavy Dirac or Majorana neutrino. This explicit violation of the decoupling theorem [27] has recently been observed for the one-loop vertex functions  $Zl'$  and  $Hl'$  (with  $l \neq l'$ ) in “see-saw” models [10,11]. The effective couplings  $Zl'$  and  $Hl'$  show a similar strong quadratic dependence of the heavy neutrino mass. Among the various decay processes, we find numerically that the decays,  $\tau \rightarrow e^- e^- e^+$  and  $\tau \rightarrow e^- \mu^- \mu^+$ , have the biggest opportunity to be detected at the present or future LEP data. Especially, the effect of genuine Majorana-neutrino contributions to the charged lepton decays is also analyzed quantitatively.

The present work is organized as follows: In Section 2 we give a brief description of the basic low-energy structure of a GUT- and superstring-inspired SM. In Section 3, we discuss general constraints that should be imposed on these models. Analytically, Section 3.1 considers possible constraints based on the assumption that the model should generate

a sufficiently large lepton asymmetry via the out-of-equilibrium  $L$ -violating decays of a heavy Majorana neutrino which can be converted later on into the observed baryon-number ( $B$ ) asymmetry in the universe (BAU) due to the sphaleron interactions. In section 3.2, stringent constraints of possible non-SM mixings are derived by a global analysis of all existing low-energy data. Also, bounds that may be obtained by the non-observation of leptonic non-diagonal  $Z$ -boson decays at LEP are discussed in Section 3.3. In Section 4, we analytically calculate the branching ratios of the photonic decays of a lepton ( $l$ ),  $l \rightarrow l'\gamma$ , and the three-body decay modes of the type  $l \rightarrow l'l_1\bar{l}_2$  in the context of the models discussed in Section 2. Numerical predictions and discussion of these lepton-flavour-violating decays are summarized in Section 5. We draw our conclusions in Section 6.

## 2 Theoretical models

In this section, we will give a short description of the basic low-energy structure of the two most popular extensions of the SM that can naturally account for very light or strictly massless neutrinos. The field content of these models is inspired by heterotic superstring models [2] or certain  $SO(10)$ -GUTs [3,22] and is free of anomalies [25]. These two scenarios are the interfamily “see-saw” model realized in the SM with right-handed neutrinos [3,7,5] and the SM with left-handed and right-handed neutral singlets [2,23,24].

Interfamily “see-saw” models, being invariant under the SM gauge group, represent one of the most natural framework to predict heavy Majorana neutrinos. After the introduction of a number  $n_R$  of right-handed neutrinos,  $\nu_{Ri}^0$ , in addition to  $n_G$  left-handed ones,  $\nu_{Li}^0$ , which also allows the presence of  $\Delta L = 2$  operators through Majorana masses, the Yukawa sector of such a minimal extension of the SM is written down as

$$-\mathcal{L}_Y^\nu = \frac{1}{2}(\bar{\nu}_L^0, \bar{\nu}_R^{0C}) M^\nu \begin{pmatrix} \nu_L^{0C} \\ \nu_R^0 \end{pmatrix} + H.c., \quad (2.1)$$

where the  $(n_G + n_R) \times (n_G + n_R)$ -dimensional neutrino-mass matrix

$$M^\nu = \begin{pmatrix} 0 & m_D \\ m_D^T & m_M \end{pmatrix} \quad (2.2)$$

has the known “see-saw” form [3]. The matrix  $M^\nu$  can always be diagonalized by a unitary matrix  $U^\nu$  of the same dimensionality with the neutrino-mass matrix (*i.e.*,  $U^{\nu T} M^\nu U^\nu = \hat{M}^\nu$ ). One then gets  $n_G + n_R$  physical Majorana neutrinos  $n_i$  through the unitary transformations

$$\begin{pmatrix} \nu_L^0 \\ \nu_R^{0C} \end{pmatrix}_i = \sum_{j=1}^{n_G+n_R} U_{ij}^{\nu*} n_{Lj} \quad \text{and} \quad \begin{pmatrix} \nu_L^{0C} \\ \nu_R^0 \end{pmatrix}_i = \sum_{j=1}^{n_G+n_R} U_{ij}^\nu n_{Rj}. \quad (2.3)$$

The first  $n_G$  neutral states,  $\nu_i$  ( $\equiv n_i$  for  $i = 1, \dots, n_G$ ), are identified with the known  $n_G$  light neutrinos (*i.e.*,  $n_G = 3$ ), while the remaining  $n_R$  mass eigenstates,  $N_j$  ( $\equiv n_{j+n_G}$  for  $j = 1, \dots, n_R$ ), represent heavy Majorana neutrinos which are novel particles predicted by the model. The quark sector of such an extension is standard and can completely be given by the SM.

Adopting the conventions of Ref. [5], the interactions of the Majorana neutrinos,  $n_i$ , and charged leptons,  $l_i$ , with the gauge bosons,  $W^\pm$  and  $Z$ , and the unphysical Goldstone bosons,  $G^\pm$  and  $G^0$  (in the Feynman-'t Hooft gauge), are correspondingly obtained by the Lagrangians:

$$\mathcal{L}_{int}^W = -\frac{g_w}{\sqrt{2}} W^{-\mu} \sum_{i=1}^{n_G} \sum_{j=1}^{n_G+n_R} B_{l_i,j} \bar{l}_i \gamma_\mu P_L n_j + H.c., \quad (2.4)$$

$$\mathcal{L}_{int}^Z = -\frac{g_w}{4c_w} Z^\mu \sum_{i,j=1}^{n_G+n_R} \bar{n}_i \gamma_\mu [i \text{Im} C_{ij} - \gamma_5 \text{Re} C_{ij}] n_j \quad (2.5)$$

and

$$\mathcal{L}_{int}^{G^\mp} = -\frac{g_w}{\sqrt{2} M_W} G^\mp \sum_{i=1}^{n_G} \sum_{j=1}^{n_G+n_R} B_{l_i,j} \bar{l}_i [m_{l_i} P_L - m_j P_R] n_j + H.c., \quad (2.6)$$

$$\mathcal{L}_{int}^{G^0} = \frac{ig_w}{4M_W} G^0 \sum_{i,j=1}^{n_G+n_R} \bar{n}_i [\gamma_5 (m_i + m_j) \text{Re} C_{ij} + i(m_j - m_i) \text{Im} C_{ij}] n_j. \quad (2.7)$$

where  $P_L(P_R) = (1 + (-)\gamma_5)/2$  and  $m_i$  denotes all the physical neutrino masses. In Eqs. (2.4)–(2.7),  $B$  and  $C$  are  $n_G \times (n_R + n_G)$ - and  $(n_G + n_R) \times (n_R + n_G)$ -dimensional matrices, respectively, which are defined as

$$B_{l_i,j} = \sum_{k=1}^{n_G} V_{l_i,k}^l U_{kj}^{\nu*} \quad \text{and} \quad C_{ij} = \sum_{k=1}^{n_G} U_{ki}^\nu U_{kj}^{\nu*}, \quad (2.8)$$

where  $V^l$  is the leptonic Cabbibo-Kobayashi-Maskawa (CKM) matrix.

Note that the flavour-mixing matrices  $B$  and  $C$  satisfy a number of identities, which are derived just by using the information of  $SU(2)_L \otimes U(1)_Y$  invariance of  $\mathcal{L}_Y^\nu$ . These identities, which guarantee the renormalizability of the interfamily “see-saw” model, can be summarized as [11,5]

$$\sum_{k=1}^{n_G+n_R} B_{l_1 k} B_{l_2 k}^* = \delta_{l_1 l_2}, \quad \sum_{k=1}^{n_G+n_R} C_{ik} C_{jk}^* = C_{ij}, \quad \sum_{k=1}^{n_G+n_R} B_{lk} C_{ki} = B_{li}, \quad \sum_{k=1}^{n_G} B_{l_k i}^* B_{l_k j} = C_{ij}, \quad (2.9)$$

$$\sum_{k=1}^{n_G+n_R} m_k C_{ik} C_{jk} = 0, \quad \sum_{k=1}^{n_G+n_R} m_k B_{lk} C_{ki}^* = 0, \quad \sum_{k=1}^{n_G+n_R} m_k B_{l_1 k} B_{l_2 k} = 0. \quad (2.10)$$

Consequently, our theoretical analysis should be regarded to be independent of the weak-basis structure of possible neutrino-mass-matrix ansätze [28]. It is also instructive to re-express the  $Z$ -boson coupling to the Majorana neutrinos,  $n_i$ , as follows:

$$\mathcal{L}_{int}^Z = -\frac{g_w}{4c_w} Z^\mu \sum_{i,j=1}^{n_G+n_R} \bar{n}_i \gamma_\mu [C_{ij} P_L - C_{ij}^* P_R] n_j. \quad (2.11)$$

One can thus remark that the coupling  $Z n_i n_j$  is generally flavour non-diagonal and has both chiralities in this minimal model.

Another attractive scenario predicting for the light neutrinos to be strictly massless serves a superstring-inspired extension of the SM, in which left-handed neutral singlets,  $S_{Li}$ , in addition to the right-handed neutrinos,  $\nu_{Ri}^0$ , have been introduced. For the sake of simplicity, we will assume that  $\Delta L = 2$  interactions are absent in the model, and the number of right-handed neutrinos,  $n_R$ , equals the number of the singlet fields  $S_{Li}$ . After the spontaneous break-down of the SM gauge symmetry, the Yukawa sector relevant for the neutrino masses reads [2,22]

$$-\mathcal{L}_Y^\nu = \frac{1}{2} (\bar{\nu}_L^0, \bar{\nu}_R^{0C}, \bar{S}_L) \mathcal{M}^\nu \begin{pmatrix} \nu_L^{0C} \\ \nu_R^0 \\ S_L^C \end{pmatrix} + H.c., \quad (2.12)$$

where the  $(n_G + 2n_R) \times (n_G + 2n_R)$  neutrino-mass matrix is given by

$$\mathcal{M}^\nu = \begin{pmatrix} 0 & m_D & 0 \\ m_D^T & 0 & M \\ 0 & M^T & 0 \end{pmatrix}. \quad (2.13)$$



Since the rank of the neutrino matrix in Eq. (2.13) is  $2n_R$ ,  $\mathcal{M}^\nu$  has  $n_G$  zero eigenvalues. These  $n_G$  massless eigenstates should clearly describe the ordinary light neutrinos,  $\nu_e$ ,  $\nu_\mu$  and  $\nu_\tau$  [2,22]. The remaining  $2n_R$  Weyl fermions are degenerate in pairs due to the fact that  $L$  is conserved and so form  $n_R$  heavy Dirac neutrinos. A nice feature of the model is that the individual leptonic quantum numbers may be violated [23,24,29]. The charged-current Lagrangian can be obtained by Eq. (2.4), while the neutral-current interaction is given by [23]

$$\mathcal{L}_{int}^Z = -\frac{g_w}{2c_w} Z^\mu \sum_{i,j=1}^{n_G+n_R} \bar{n}_i C_{ij} \gamma_\mu P_L n_j. \quad (2.14)$$

The matrices  $B$  and  $C$  for this specific model obey the sum rules in Eq. (2.9), but not the identities of Eq. (2.10).

At this stage, we must comment on the difference between the Lagrangians (2.5) and (2.14). Since Eq. (2.5) describe Majorana neutrinos contrary to the Lagrangian (2.14) where the massive neutrinos are Dirac, the strength of the  $Z\bar{n}_i n_i$  coupling for identical Majorana fermions is two times larger than the one which may naively be read off from  $\mathcal{L}_{int}^Z$  in Eqs. (2.5) and (2.11). The off-diagonal coupling  $Z\bar{n}_i n_j$  (with  $n_i \neq n_j$ ) is again enhanced by a factor of two, since the charge-conjugate interaction  $Z\bar{n}_j n_i$  will equally contribute to the coupling of the  $Z$ -boson to Majorana neutrinos. In our forthcoming calculations, we have taken into account all these theoretical differences in treating Majorana and Dirac fields. In fact, we find that taking formally the limit  $C_{ij}^* \rightarrow 0$  but keeping  $C_{ij} \neq 0$  in Eq. (2.11) and considering the afore-mentioned statistical Majorana factors is sufficient to recover the model with additional left-handed neutral singlets.

To make life easier, we ultimately make the following reasonable assumptions: To a good approximation, we assume that possible novel particles related to the above unified theories, such as leptoquarks [30] or extra charged and neutral gauge bosons,  $W_R^\pm$  [31] and  $Z'$  [32,20], are sufficiently heavy so as to decouple completely from the low-energy processes discussed in Sections 3.3 and 4. For obvious reasons, possible singlet and triplet Majoron fields [33–36] are considered to couple very weakly to matter so that we can safely ignore them in our considerations.

### 3 General constraints on the models

#### 3.1 Constraints from sphaleron erasure of the BAU

Unified theories based on the gauge group  $SO(10)$  or  $E_6$  can naturally accommodate right-handed neutrinos in addition to quarks and leptons of the SM. In such theories, the Majorana mass  $m_M$  can directly be related to the  $B - L$  scale of a local symmetry which is assumed to be spontaneously broken. It is therefore evident that the mass of heavy Majorana neutrinos will be determined by the scale of  $B - L$  breaking. Moreover, out-of-equilibrium lepton-number-violating decays of heavy Majorana neutrinos can generate a non-zero  $L$  [37] in the universe through the  $L$ -violating interactions of Eqs. (2.4)–(2.7). This excess in  $L$  can be converted into a  $B$  asymmetry of the universe via the  $(B + L)$ -violating sphaleron interactions, which are in thermal equilibrium above the critical temperature of the electroweak phase transition [38,39]. Many studies have recently been devoted to constrain the  $(B - L)$ -violating mass scale by making use of the drastic out-of-equilibrium condition for the  $\Delta L = 2$  operators, and so to derive a lower mass bound on the heavy Majorana neutrinos [40–44]. For example, in [40] conceivable scenarios predicting heavy Majorana neutrinos with  $m_N = 1 - 10$  TeV could naturally account for the observed BAU. Subsequently, it was argued [41] that the  $m_N$  lower bound of  $\sim 1$  TeV was considerably underestimated and a lower bound on  $m_N > 10^5$  TeV should be imposed in a two-generation scenario of right-handed neutrinos with large interfamily mixings so as to be compatible with the existing BAU. This would obviously imply that probing Majorana-neutrino physics at collider energies may not be phenomenologically interesting.

The latter observation can indeed be valid in a two-generation-mixing model with two right-handed neutrinos. In general, in three-generation models with lepton-flavour mixings, a careful inspection of chemical potentials has shown that the stringent mass bound of heavy Majorana neutrinos mentioned above can be weakened dramatically and is quite model dependent [43,44]. In particular, it is sufficient that in equilibrium state one individual lepton number, *e.g.*  $L_\mu$ , is conserved in order to generate the BAU via the sphaleron interactions, even if non-vanishing operators with  $\Delta L_i \neq \Delta L_\mu$  were in thermal equilibrium [43]. The reason is that sphalerons generally conserve the quantum numbers

$B/3 - L_i$ , [42,43] and thus preserve any BAU generated by an excess, *e.g.*, in  $L_\mu$ , from being washed out. Similar conclusions have been drawn in Ref. [44].

A viable scenario of heavy Majorana neutrinos with masses  $\sim$  TeV can easily be realized in the SM with  $n_R = 4$ . If the BAU is to be generated through an excess in muonic number density, this asymmetry in  $L_\mu$  can be achieved by considering a neutrino mass matrix,  $M^\nu$ , similar to the  $CP$ -violating scenario given in [17]. This scenario contains one left-handed neutrino,  $\nu_{L1}^0$ , to which, for the case at hand, a muonic quantum number should be assigned, and two right-handed neutrinos, denoted as  $\nu_{R3}^0$  and  $\nu_{R4}^0$ . The explicit form of  $M^\nu$  is then given by [17]

$$M^\nu = \begin{pmatrix} 0 & a & b \\ a & A & 0 \\ b & 0 & B \end{pmatrix}, \quad (3.1)$$

where  $a$  and  $b$  are in general complex numbers, and  $A$  and  $B$  can be chosen to be real. Out-of-equilibrium conditions for generating a sufficiently large asymmetry in  $L_\mu$ , which can give rise to the established BAU, lead to the stringent lower bounds on the masses of the corresponding physical heavy neutrinos  $N_{3,4}$  as consistently obtained by [41]. However, the remaining  $e$ - and  $\tau$ -lepton families can strongly mix each other via two *additional* right-handed neutrinos, *e.g.*,  $\nu_{R1}^0$  and  $\nu_{R2}^0$ , and form an *individual*  $4 \times 4$  “see-saw” matrix. Operators  $\Delta L_e \neq 0$  and  $\Delta L_\tau \neq 0$  are now allowed to be in thermal equilibrium provided that  $\Delta(L_e - L_\mu) = 0$  and  $\Delta(L_\tau - L_\mu) = 0$ . The latter condition is automatically satisfied due to the construction of this specific scenario with  $n_R = 4$ . As a consequence, the severe lower mass bounds on the physical heavy neutrinos  $N_1$  and  $N_2$  can be evaded completely. A similar analysis in a SM with  $n_R = 3$  is more involved due to the flavour-mixing effects in the neutrino-mass matrix and can be given elsewhere.

## 3.2 Low-energy constraints

There exists a great number of low-energy experiments that could set upper bounds on possible non-SM couplings [19]. The most significant experimental tests giving stringent constraints turn out to be the neutrino counting at the  $Z$  peak, the precise measurement of the muon width  $\mu \rightarrow e\nu_e\nu_\mu$ , charged-current universality effects in the observable  $\Gamma(\pi \rightarrow$

$e\nu)/\Gamma(\pi \rightarrow \mu\nu)$ , non-universality effects in the quantity  $B(\tau \rightarrow e\nu\nu)/B(\tau \rightarrow \mu\nu\nu)$ , and other nuclear physics effects and experiments. All these constraints, which are derived by the low-energy data mentioned above, depend crucially on the gauge structure of the model under discussion. For example, assuming the supersymmetric (SUSY) nature of the  $E_6$  models or SUSY- $SO(10)$  unified theories [45,46], and  $R$ -parity invariance, the neutralino state could then be the lightest supersymmetric particle (LSP) which is stable. If the mass of the LSP is assumed to be in the vicinity of  $M_Z/2$ , then an additional invisible decay channel for the  $Z$  boson will open kinematically and neutrino-counting limits imposed on the couplings  $Z\nu_i\nu_j$  may not be applicable. Furthermore, caveats arising from decays of the type  $Z \rightarrow N\nu$ , which may provide  $Z$  boson by an additional invisible decay mode, could also be present [26].

Thus, identifying the non-SM-mixing angles  $(s_L^{\nu_i})^2$  of Ref. [19] as

$$(s_L^{\nu_i})^2 \equiv \sum_{j=1}^{n_R} |B_{l_i N_j}|^2, \quad (3.2)$$

and in view of the discussion given above, one may tolerate the following upper limits [19]:

$$(s_L^{\nu_e})^2 < 0.015, \quad (s_L^{\nu_\tau})^2 < 0.070, \quad \text{and} \quad (s_L^{\nu_\mu})^2 < 1.10^{-9}. \quad (3.3)$$

Another limitation to the parameters of our model comes from the requirement of the validity of perturbative unitarity that can be violated in the limit of large heavy-neutrino masses. A safe estimate for the latter may be obtained by requiring that the total widths,  $\Gamma_{N_i}$ , and masses of neutrino fields  $N_i$  satisfy the inequality

$$\frac{\Gamma_{N_i}}{m_{N_i}} < \frac{1}{2}. \quad (3.4)$$

The total widths of the heavy neutrinos,  $\Gamma_{N_i}$ , can be written down as a sum over all possible decay channels [5], *i.e.*

$$\Gamma_{N_i} = \sum_{l_j} \Gamma(N_i \rightarrow l_j^\pm W^\mp) + \sum_{\nu_j} \left( \Gamma(N_i \rightarrow \nu_j Z) + \Gamma(N_i \rightarrow \nu_j H) \right). \quad (3.5)$$

In the limit of  $m_{N_i} \gg M_W, M_Z, M_H$ , the above expression can significantly be simplified as

$$\Gamma_{N_i} = \frac{\alpha_w}{4M_W^2} m_{N_i}^3 |C_{N_i N_i}|^2. \quad (3.6)$$

Expression (3.6) is independent of the nature of the heavy neutrinos  $N_i$ , which could be of the Majorana or Dirac type.

### 3.3 Constraints from leptonic $Z$ -boson decays

Aside from low-energy constraints discussed in Section 3.2, many extensions of the SM derived by unified theories may give rise to sizeable lepton-flavour-violating decays of the  $Z$  boson [47]. In particular, it has been found in [10] that the non-observation of such non-SM signals at LEP may impose combined bounds both on heavy neutrino masses  $m_{N_i}$  and mixings  $(s_L^{\nu_i})^2$ . The reason is that the amplitude of such a decay increase quadratically with the heavy neutrino mass and thus violates the decoupling theorem [27]. In a self-explanatory way, the amplitude of the decay  $Z \rightarrow ll'$  may generally be parametrized as

$$\mathcal{T}(Z \rightarrow \bar{l}l') = \frac{ig_w \alpha_w}{8\pi c_w} \mathcal{F}_Z^{ll'} \varepsilon_Z^\mu \bar{u}_{l'} \gamma_\mu (1 - \gamma_5) v_l, \quad (3.7)$$

where  $\alpha_w = g_w^2/4\pi$  and the form factor  $\mathcal{F}_Z^{ll'}$ , which is induced by the Feynman graphs of Fig. 2 at the one-loop electroweak order, is given in Appendix A. The branching ratio of this decay mode is obtained by

$$B(Z \rightarrow \bar{l}l' + \bar{l}'l) = \frac{\alpha_w^3}{48\pi^2 c_w^3} \frac{M_W}{\Gamma_Z} |\mathcal{F}_Z^{ll'}|^2, \quad (3.8)$$

where  $\Gamma_Z = 91.173$  GeV is the experimental value of the total width of the  $Z$  boson [49]. In particular, interfamily “see-saw” models with more than one right-handed neutrino can dramatically relax the severe limits on  $s_L^{\nu_i} \sim \sqrt{m_{\nu_i}/m_N}$  as usually derived in a one-family “see-saw” scenario [48], and thus predict sizeable lepton-flavour-violating decays of the  $Z$  and  $H$  particles that can be probed at high-energy colliders [11,10]. A similar enhancement of non-universality effects in leptonic  $Z$ -boson decays due to the non-decoupling physics introduced by heavy Majorana neutrinos has recently been studied in [12]. In fact, it has been shown [12] that the decay amplitude relevant for such effects can be up to 10 times bigger than the naive value obtained by neglecting seemingly suppressed terms proportional to  $(s_L^{\nu_i})^4$ . We postpone the numerical discussion of possible constraints arising due to lepton-flavour-violating decays of the  $Z$  boson in Section 5.

## 4 Flavour-violating decays of charged leptons

In Sections 4.1 and 4.2, we will theoretically analyze the possibility of lepton flavour

non-conservation in decays of the form  $l \rightarrow l'\gamma$  and  $l \rightarrow l'l_1\bar{l}_2$ , respectively. As mentioned in the Introduction,  $l, l', l_1$  and  $l_2$  denote usual charged leptons, *i.e.* the  $e, \mu$  and  $\tau$  leptons.

#### 4.1 The decay $l \rightarrow l'\gamma$

In the framework of the minimal class of models discussed in Section 2, heavy Majorana or Dirac neutrinos can give rise to the decay  $l \rightarrow l'\gamma$ . The Feynman graphs responsible for such a decay are shown in Fig. 1. Applying electromagnetic gauge invariance to the decay amplitude  $l(p) \rightarrow l'(p')\gamma(q)$ , where the photon,  $\gamma$ , may be off-mass shell, yields [51,52]

$$\begin{aligned} T(l \rightarrow l'\gamma) = & -i \frac{e\alpha_w}{16\pi M_W^2} \varepsilon_\gamma^\mu \bar{u}_{l'} \left[ \sum_{i=1}^{n_G+n_R} B_{li}^* B_{l'i} F_\gamma(\lambda_i) (q^2 \gamma_\mu - \not{q} q_\mu) (1 - \gamma_5) \right. \\ & \left. - \sum_{i=1}^{n_G+n_R} B_{li}^* B_{l'i} G_\gamma(\lambda_i) i\sigma_{\mu\nu} q^\nu (m_{l'}(1 - \gamma_5) + m_l(1 + \gamma_5)) \right] u_l, \end{aligned} \quad (4.1)$$

where  $\lambda_i = m_i^2/M_W^2$ ,  $q = p - p'$  denotes the outgoing momentum of the photon, and the form factors  $F_\gamma$  and  $G_\gamma$  are given in Appendix B. It is now straightforward to calculate the branching ratio of  $l \rightarrow l'\gamma$

$$B(l \rightarrow l'\gamma) = \frac{\alpha_w^3 s_w^2}{256\pi^2} \frac{m_l^4}{M_W^4} \frac{m_l}{\Gamma_l} |G_\gamma^{ll'}|^2, \quad (4.2)$$

where  $\Gamma_l$  is the total width of the decaying lepton  $l$ , while  $G_\gamma^{ll'}$  in Eq. (4.2) represents a composite form factor defined in Appendix B. Specifically, for the total width of the  $\tau$  lepton, we use the experimental value,  $\Gamma_\tau = 2.1581 \cdot 10^{-12}$  GeV [49], whereas the muon total width may be obtained by [50]

$$\Gamma_\mu = \frac{G_F^2 m_\mu^5}{192\pi^3} \left( 1 - 8 \frac{m_e^2}{m_\mu^2} \right) \left[ 1 + \frac{\alpha_{em}}{2\pi} \left( \frac{25}{4} - \pi^2 \right) \right], \quad (4.3)$$

where  $\alpha_{em} = e^2/4\pi$ . The muon total width given in Eq. (4.3) is in excellent agreement with the experimental value reported in [49].

The experimental upper bounds arising from the non-observation of decays of the type  $l \rightarrow l'\gamma$  are [49]

$$B(\tau \rightarrow e\gamma) < 5.5 \cdot 10^{-5}, \quad B(\tau \rightarrow \mu\gamma) < 2 \cdot 10^{-5}, \quad B(\mu \rightarrow e\gamma) < 4.9 \cdot 10^{-11}, \quad (4.4)$$

at 90% CL. Using the values for the mixing angles  $(s_L^{\nu_i})^2$  of Eq. (3.3), one easily finds that the photonic decays involving muons are extremely suppressed in our minimal scenarios.

Furthermore, the theoretical prediction  $B(\tau \rightarrow e\gamma) \lesssim 10^{-7}$  shows that photonic decays of a  $\tau$  lepton is not the most favourable place to probe heavy neutrino physics.

## 4.2 Three-body leptonic decays $l \rightarrow l'l_1\bar{l}_2$

In a three-generation model the decaying charged lepton  $l$  will either be a muon or a  $\tau$  lepton. There are seven possible decays of the generic form  $l \rightarrow l'l_1\bar{l}_2$

$$\begin{aligned}
\text{a. } & \tau^- \rightarrow \mu^- \mu^- \mu^+, \\
\text{b. } & \tau^- \rightarrow \mu^- \mu^- e^+, \\
\text{c. } & \tau^- \rightarrow e^- \mu^- \mu^+, \\
\text{d. } & \tau^- \rightarrow e^- e^- \mu^+, \\
\text{e. } & \tau^- \rightarrow e^- \mu^- e^+, \\
\text{f. } & \tau^- \rightarrow e^- e^- e^+, \\
\text{g. } & \mu^- \rightarrow e^- e^- e^+.
\end{aligned} \tag{4.5}$$

To facilitate our computational task, we divide the decays in Eq. (4.5) into three categories according to the leptonic flavours in the final state: Category (i) contains all the decays where  $l' \neq l_2$  and  $l_1 = l_2$  or  $l' = l_2$  and  $l_1 \neq l_2$  (*i.e.* the decays (c) and (e)). Category (ii) comprises all the decays where  $l' = l_1 = l_2$  (*i.e.* the decays (a), (f) and (g)). And lastly, all the decays with final leptons having  $l' \neq l_2$ ,  $l_1 \neq l_2$  belong to the category (iii) (*i.e.* the decays (b) and (d)).

The transition amplitude of the decay  $l(p) \rightarrow l'(p')l_1(p_1)\bar{l}_2(p_2)$  receives contributions from  $\gamma$ - and  $Z$ -mediated graphs shown in Fig. 1 and 2, respectively, and box diagrams given in Fig. 3. These three different amplitudes are conveniently written down as follows:

$$\begin{aligned}
\mathcal{T}_\gamma(l \rightarrow l'l_1\bar{l}_2) &= -\frac{i\alpha_w^2 s_w^2}{4M_W^2} \delta_{l_1 l_2} \sum_{i=1}^{n_G+n_R} B_{li}^* B_{l'i} \bar{u}_{l_1} \gamma^\mu v_{l_2} \bar{u}_{l'} [F_\gamma(\lambda_i)(\gamma_\mu - \frac{q_\mu \not{q}}{q^2})(1 - \gamma_5) \\
&\quad - iG_\gamma(\lambda_i) \sigma_{\mu\nu} \frac{q^\nu}{q^2} (m_l(1 + \gamma_5) + m_{l'}(1 - \gamma_5))] u_l,
\end{aligned} \tag{4.6}$$

$$\mathcal{T}_Z(l \rightarrow l'l_1\bar{l}_2) = -\frac{i\alpha_w^2}{16M_W^2} \bar{u}_{l'} \gamma_\mu (1 - \gamma_5) u_l \bar{u}_{l_1} \gamma^\mu (1 - 4s_w^2 - \gamma_5) v_{l_2}$$

$$\times \delta_{l_1 l_2} \sum_{i,j=1}^{n_G+n_R} B_{li}^* B_{lj} [ \delta_{ij} F_Z(\lambda_i) + C_{ij} H_Z(\lambda_i, \lambda_j) + C_{ij}^* G_Z(\lambda_i, \lambda_j) ], \quad (4.7)$$

$$\begin{aligned} \mathcal{T}_{Box}(l \rightarrow l' l_1 \bar{l}_2) &= -\frac{i\alpha_w^2}{16M_W^2} \bar{u}_{l'} \gamma_\mu (1 - \gamma_5) u_l \bar{u}_{l_1} \gamma^\mu (1 - \gamma_5) v_{l_2} \\ &\times \sum_{i,j=1}^{n_G+n_R} [ (B_{li} B_{lj} + B_{l_1 i} B_{l_1 j}) B_{li}^* B_{l_2 j}^* F_{Box}(\lambda_i, \lambda_j) \\ &+ B_{li} B_{l_1 i} B_{lj}^* B_{l_2 j}^* G_{Box}(\lambda_i, \lambda_j) ], \end{aligned} \quad (4.8)$$

where  $q = p_1 + p_2$ . In addition to the photonic form factors  $F_\gamma$  and  $G_\gamma$  in Eq. (4.6), the form factors  $F_Z$ ,  $H_Z$ ,  $G_Z$ ,  $F_{Box}$ , and  $G_{Box}$  are given in Appendix B. Note that the term proportional to  $G_\gamma$  in Eq. (4.6) contains a non-local interaction which is singular in the limit  $q^2 \rightarrow 0$ .

Following the classification mentioned above, the branching ratio for all decays belonging to the first category is found to be \*

$$\begin{aligned} B(l^- \rightarrow l' l_1^- l_2^+, l' \neq l_2, l_1 = l_2) &= \frac{\alpha_w^4}{24576\pi^3} \frac{m_l^4}{M_W^4} \frac{m_l}{\Gamma_l} \\ &\times \left\{ |F_{Box}^{ll'l_1 l_1} + F_Z^{ll'} - 2s_w^2 (F_Z^{ll'} - F_\gamma^{ll'})|^2 + 4s_w^4 |F_Z^{ll'} - F_\gamma^{ll'}|^2 \right. \\ &+ 8s_w^2 \text{Re}[(F_Z^{ll'} + F_{Box}^{ll'l_1 l_1}) G_\gamma^{ll'*}] - 32s_w^4 \text{Re}[(F_Z^{ll'} - F_\gamma^{ll'}) G_\gamma^{ll'*}] \\ &\left. + 32s_w^4 |G_\gamma^{ll'}|^2 \left[ \ln \frac{m_l^2}{m_{l_1}^2} - 3 \right] \right\}, \end{aligned} \quad (4.9)$$

where  $F_\gamma^{ll'}$ ,  $G_\gamma^{ll'}$ ,  $F_Z^{ll'}$ , and  $F_{Box}^{ll'l_1 l_2}$  are composite form factors defined explicitly in Appendix B. The branching ratios referring to the categories (ii) and (iii) are correspondingly given by

$$\begin{aligned} B(l^- \rightarrow l' l_1^- l_2^+, l' = l_1 = l_2) &= \frac{\alpha_w^4}{24576\pi^3} \frac{m_l^4}{M_W^4} \frac{m_l}{\Gamma_l} \\ &\times \left\{ 2 \left| \frac{1}{2} F_{Box}^{ll_1 l_1 l_1} + F_Z^{ll_1} - 2s_w^2 (F_Z^{ll_1} - F_\gamma^{ll_1}) \right|^2 + 4s_w^4 |F_Z^{ll_1} - F_\gamma^{ll_1}|^2 \right. \\ &+ 16s_w^2 \text{Re}[(F_Z^{ll_1} + \frac{1}{2} F_{Box}^{ll_1 l_1 l_1}) G_\gamma^{ll_1*}] - 48s_w^4 \text{Re}[(F_Z^{ll_1} - F_\gamma^{ll_1}) G_\gamma^{ll_1*}] \\ &\left. + 32s_w^4 |G_\gamma^{ll_1}|^2 \left[ \ln \frac{m_l^2}{m_{l_1}^2} - \frac{11}{4} \right] \right\} \end{aligned} \quad (4.10)$$

and

$$B(l^- \rightarrow l' l_1^- l_2^+, l_1 \neq l_2, l' \neq l_2) = \frac{\alpha_w^4}{49152\pi^3} \frac{m_l^4}{M_W^4} \frac{m_l}{\Gamma_l} |F_{Box}^{ll'l_1 l_2}|^2. \quad (4.11)$$

---

\*In our calculations we have used a notation similar to the authors in [29]. However, our branching-ratio expressions (4.9) and (4.10) are at variance with their results.



Equations (4.9) and (4.10) contain a non-local interaction in terms  $\propto G_\gamma^{ll'}$  and  $G_\gamma^{ll_1}$ , which is discussed in detail in Appendix C. In Eq. (4.10), one has to take into account statistical symmetrization factors for the two identical final leptons (*i.e.*  $l' = l_1$ ), as well as additional Feynman graphs resulting from the interchange of the lepton  $l'$  with  $l_1$ . The set of decays in (iii) can only be induced by the box graphs shown in Fig. 3. The amplitude of such a class of decays (*i.e.* decays (b) and (d)) is always proportional to  $(s_L^{\nu_l})^2 s_L^{\nu_e} s_L^{\nu_\mu}$  and the corresponding branching ratios are hence expected to be vanishingly small even if one uses the upper value of  $s_L^{\nu_\mu}$  in Eq. (3.3). For reasons of mere academic interest, we simply note that  $B(\tau^- \rightarrow e^- e^- \mu^+), B(\tau^- \rightarrow \mu^- \mu^- e^+) \lesssim 10^{-12}$ . As a consequence, we find that the decays (c) and (f) in Eq. (4.5) deserve the biggest attention and will hence be analyzed numerically in the next section.

## 5 Numerical evaluation and discussion

We will now investigate the phenomenological impact of those theories that contain heavy Dirac or Majorana neutrinos. In order to pin down numerical predictions, we will, for definiteness, assume an extension of the SM by two right-handed neutrinos. The neutrino mass spectrum of such a model consists of three light Majorana neutrinos which have been identified with the three known neutrinos,  $\nu_e$ ,  $\nu_\mu$ , and  $\nu_\tau$ , and two heavy ones denoted by  $N_1$  and  $N_2$ . As already mentioned in Section 2, the SM inspired by superstring theories with an  $E_6$  symmetry [2], in which one left-handed and one right-handed chiral singlets are present, can effectively be recovered by the SM with two right-handed neutrinos when going to the degenerate mass limit for the two heavy Majorana neutrinos. It is therefore obvious that branching-ratio results for the SM with one left-handed and one right-handed neutral singlets can be red off from the SM with two right-handed neutrinos in the specific case  $m_{N_1} = m_{N_2} = m_N$ .

Apart from the two heavy Majorana neutrino masses which are free parameters of the theory, the model contains numerous mixing angles,  $B_{li}$  and  $C_{ij}$ , for which the only restriction comes from a low-energy analysis as discussed in Sections 3.2 and 3.3. However, in our minimal model with two right-handed neutrinos one can derive, with the help of the

identities in Eqs. (2.9) and (2.10), the useful relations

$$B_{1N_1} = \frac{\rho^{1/4} s_L^{\nu_1}}{\sqrt{1 + \rho^{1/2}}}, \quad B_{1N_2} = \frac{i s_L^{\nu_1}}{\sqrt{1 + \rho^{1/2}}}, \quad (5.1)$$

where  $\rho = m_{N_2}^2/m_{N_1}^2$ . The mixings  $C_{N_i N_j}$  can also be obtained by employing Eq. (2.9). In this way, one gets

$$\begin{aligned} C_{N_1 N_1} &= \frac{\rho^{1/2}}{1 + \rho^{1/2}} \sum_{i=1}^{n_G} (s_L^{\nu_i})^2, & C_{N_2 N_2} &= \frac{1}{1 + \rho^{1/2}} \sum_{i=1}^{n_G} (s_L^{\nu_i})^2, \\ C_{N_1 N_2} &= -C_{N_2 N_1} = \frac{i \rho^{1/4}}{1 + \rho^{1/2}} \sum_{i=1}^{n_G} (s_L^{\nu_i})^2. \end{aligned} \quad (5.2)$$

Evidently, our minimal scenario depends only on the masses of the heavy Majorana neutrinos,  $m_{N_1}$  and  $m_{N_2}$  (or equivalently on  $m_{N_1}$  and  $\rho$ ), and the mixing angles  $(s_L^{\nu_i})^2$ , which are directly constrained by a global analysis of low-energy data.

In our illustrative model, with the help of Eq. (5.2), we can easily obtain the maximal heavy neutrino mass allowed by perturbative unitarity. Satisfying Eq. (3.4) for both heavy neutrinos  $N_1$  and  $N_2$ , one gets the global relation

$$m_{N_1}^2 \leq \frac{2M_W^2}{\alpha_w} \frac{1 + \rho^{-1/2}}{\rho^{1/2}} \left[ \sum_{i=1}^{n_G} (s_L^{\nu_i})^2 \right]^{-1}, \quad (5.3)$$

with  $\rho \geq 1$ . Condition (5.3) has thoroughly been used in our numerical estimates to impose an upper bound on  $m_{N_{1,2}}$ .

For reasons mentioned in Section 4.2, we present the branching ratios for the leptonic decays  $\tau^- \rightarrow e^- e^- e^+$  and  $\tau^- \rightarrow e^- \mu^- \mu^+$  in Fig. 4. To gauge to which extent our minimal model can predict measurable rates, we have first assumed the maximally allowed values [19] for  $(s_L^{\nu_\tau})^2 = 0.07$  and  $(s_L^{\nu_e})^2 = 0.015$  ( $(s_L^{\nu_\mu})^2 \simeq 0$ ) given in Eq. (3.3). From Fig. 4 we find the encouraging branching ratios

$$B(\tau^- \rightarrow e^- e^- e^+) \lesssim 2 \cdot 10^{-6} \quad \text{and} \quad B(\tau^- \rightarrow e^- \mu^- \mu^+) \lesssim 1 \cdot 10^{-6}. \quad (5.4)$$

The present experimental upper limits on these decays are given by [49]

$$B(\tau^- \rightarrow e^- e^- e^+), B(\tau^- \rightarrow e^- \mu^- \mu^+) < 2.7 \cdot 10^{-5}, \quad \text{CL} = 90\%. \quad (5.5)$$

Even if we assume smaller values for the mixing angles,  $(s_L^{\nu_\tau})^2 = 0.035$  and  $(s_L^{\nu_e})^2 = 0.01$  ( $(s_L^{\nu_\mu})^2 = 0$ ), the lepton-flavour-violating decays of the  $\tau$  lepton can still be significant.

From Fig. 5 one has that

$$B(\tau^- \rightarrow e^- e^- e^+) \lesssim 5 \cdot 10^{-7} \quad \text{and} \quad B(\tau^- \rightarrow e^- \mu^- \mu^+) \lesssim 3 \cdot 10^{-7}, \quad (5.6)$$

and the possibility of observing such decays at future LEP experiments appears feasible. Note that the branching ratio increase with the heavy neutrino mass to the fourth power and hence allows to reach measurable values. To demonstrate this fact, we have just neglected contributions of seemingly suppressed terms  $\mathcal{O}((s_L^{\nu_i})^4)$  in the transition elements and found a reduction of our numerical values up to  $\sim 10^{-2}$ . In the low-mass range of heavy neutrinos (*i.e.* for  $m_{N_i} < 200$  GeV) the difference between the two distinct computations is quite small and consistent with results obtained in [29]. In the high-mass regime, however, the situation changes drastically (see also Figs. 4 and 5), since in the transition amplitude, terms proportional to  $(s_L^{\nu_i})^2$  increase logarithmically with the heavy neutrino mass  $m_N$ , *i.e.*  $\ln(m_N^2/M_W^2)$ , while terms of  $\mathcal{O}((s_L^{\nu_i})^4)$  show a strong quadratic dependence in the heavy neutrino mass, *i.e.*  $m_N^2/M_W^2$ . A similar observation has also been made in [10,11].

Fig. 6 represents genuine Majorana-neutrino quantum effects, since we have computed the branching ratios as a function of the ratio  $m_{N_2}/m_{N_1}$  for the selective values of  $m_{N_1} = 200$  GeV and 500 GeV. Although the most stringent constraints on the heavy Majorana neutrino masses result from Eq. (5.3), it is, however, important to notice that for lower neutrino masses the maximum of  $B(\tau^- \rightarrow e^- e^- e^+)$  and  $B(\tau^- \rightarrow e^- \mu^- \mu^+)$  is not given by the degenerate case where  $\rho = 1$ . Actually, if  $m_{N_2}/m_{N_1} \simeq 3$  the branching ratios show up a maximum which can be up to two times bigger than the case where both the heavy neutrinos,  $N_1$  and  $N_2$ , are degenerate. We have thus found that for  $m_{N_1} = 500$  GeV and  $m_{N_2} \simeq 1.5$  TeV,

$$B(\tau^- \rightarrow e^- e^- e^+) \lesssim 2 \cdot 10^{-8} \quad \text{and} \quad B(\tau^- \rightarrow e^- \mu^- \mu^+) \lesssim 1.5 \cdot 10^{-8}. \quad (5.7)$$

Such effects might be accessible at  $\tau$  factories if one assumes an upgrade in the luminosity of the LEP collider by a factor of 10.

In the following, we will discuss possible constraints that might arise from lepton-flavour-violating decays of the  $Z$  boson. Since we always assume that  $(s_L^{\nu_\mu})^2 = 0$ , we will focus our analysis on the decays  $Z \rightarrow e^- \tau^+ + e^+ \tau^-$ . Within the perturbatively allowed range of heavy neutrino masses as determined by Eq. (5.3), Fig. 7 gives

$$B(Z \rightarrow e^- \tau^+ + e^+ \tau^-) \lesssim 4.0 \cdot 10^{-6}, \quad \text{for} \quad (s_L^{\nu_\tau})^2 = 0.070, \quad (s_L^{\nu_e})^2 = 0.015,$$

$$\begin{aligned}
B(Z \rightarrow e^- \tau^+ + e^+ \tau^-) &\lesssim 1.1 \cdot 10^{-6}, \quad \text{for } (s_L^{\nu\tau})^2 = 0.035, \quad (s_L^{\nu e})^2 = 0.010, \\
B(Z \rightarrow e^- \tau^+ + e^+ \tau^-) &\lesssim 6.0 \cdot 10^{-7}, \quad \text{for } (s_L^{\nu\tau})^2 = 0.020, \quad (s_L^{\nu e})^2 = 0.010. \quad (5.8)
\end{aligned}$$

Although all these branching ratios could be detected at future LEP data, they cannot impose any severe constraints on the  $\tau$  decays into three charged leptons for the present analysis. The experimental sensitivity at LEP is currently given by [49]

$$B(Z \rightarrow e^- \tau^+ + e^+ \tau^-) \lesssim 10^{-5}. \quad (5.9)$$

Of course, if a higher precision were available in experiments, one would then have to combine both the information arising from  $Z \rightarrow e\tau$  and  $\tau \rightarrow eee$  to obtain a safe numerical prediction of possible lepton-flavour-violating processes in the  $e-\tau$  system and so to impose reliable limits on the mixing angles  $(s_L^{\nu\tau})^2$  and  $(s_L^{\nu e})^2$ .

In Fig. 7, we must comment on the fact that the branching ratios for the three different mixing-angle sets in the order stated in Eq. (5.7) show a minimum at the positions  $m_N = 700, 900$  and  $1200$  GeV, respectively. The reason is that  $\mathcal{O}((s_L^{\nu i})^2)$  and  $\mathcal{O}((s_L^{\nu i})^4)$  terms of  $\mathcal{F}_Z^{ll'}$  in Eq. (3.7) cancel each other and the whole transition amplitude becomes pure absorptive. In the range of very heavy neutrinos, terms proportional to  $(s_L^{\nu i})^4$  will dominate in the amplitude for the same reasons mentioned above. The effect of such a dynamical cancellation of the dispersive part of the amplitude could be shown up as a difference between the charge-conjugate decay modes of  $Z \rightarrow e^- \tau^+$  and  $Z \rightarrow e^+ \tau^-$ , leading to sizeable  $CP$ -violating effects [24].

In Fig. 8, we display genuine Majorana-neutrino virtual effects by examining the behaviour of the branching ratio as a function of the quantity  $m_{N_2}/m_{N_1}$  for rather modest values of  $m_{N_1}$ . Here, the situation is more involved and depends strongly on the value of  $m_{N_1}$  we choose. The fact that the amplitude could be dominated by  $(s_L^{\nu i})^2$  terms for relatively light heavy Majorana neutrinos (*i.e.*  $m_{N_1} < 400$  GeV) or by  $(s_L^{\nu i})^4$  terms for larger values of  $m_{N_1}$  plays a crucial rôle for the shape of the different lines drawn in Fig. 8. The common feature is, however, that the case where both the heavy Majorana neutrinos,  $N_1$  and  $N_2$ , have the same mass does not again correspond to the situation yielding the biggest branching-ratio value.

Finally,  $\tau$  leptons can also decay hadronically via the channels:  $\tau \rightarrow l_i \eta$ ,  $\tau \rightarrow l_i \pi^0$ , etc. [29]. However, the present experimental sensitivity to these decays seems to be rather

weak [49] so as to set constraints on our analysis. For example,  $B(\tau \rightarrow e\pi^0) < 1.4 \cdot 10^{-4}$ , at CL= 90%.

## 6 Conclusions

GUT or superstring-inspired extensions of the minimal SM, which naturally contain left-handed and/or right-handed weak isosinglets, could favourably account for sizeable branching ratios of  $\tau$  decays into three charged leptons up to  $\sim 10^{-6}$  and may hence be observed at LEP. Such decays show a *quadratic* mass dependence of the heavy neutrino mass, which strongly violates the decoupling theorem [27]. Therefore, *this strong violation of the decoupling theorem gives a unique chance for such lepton-flavour-violating decays to be seen at LEP experiments or planned collider machines.*

Heavy Majorana neutrinos introduce, via loop effects, a different behaviour in the transition amplitude as compared to heavy Dirac neutrinos. We have, for example, demonstrated in Fig. 6 that an appreciably large mass difference between the two heavy Majorana neutrinos  $N_1$  and  $N_2$  (i.e.  $m_{N_2}/m_{N_1} \simeq 3$ ) gives rise to an enhancement of a factor of two to the corresponding branching-ratio value where  $m_{N_1} = m_{N_2}$ .

Apart from general constraints that our minimal model should satisfy, we have also analyzed the non-diagonal leptonic decays of the  $Z$  boson. Restricting our analysis within the range allowed by perturbative unitarity, we have found that  $B(Z \rightarrow e^-\tau^+ + e^+\tau^-) \lesssim 4 \cdot 10^{-6}$  which could be probed at LEP. It is therefore imperative to look experimentally for such signals that are forbidden in the minimal Standard Model but allowed in certain unified theories which are expected to describe the physics at the Planck mass scale such as the models considered in the present work.

**Acknowledgements.** We thank S.A. Abel, G.G. Ross, and M. Shaposhnikov for discussions about cosmological constraints on models with Majorana neutrinos, R.J.N. Phillips for useful comments, B.A. Kniehl for technical details of loop integrals, and M.C. Gonzalez-Garcia and J.W.F. Valle for remarks and comments.

## A Loop integrals of leptonic Z-boson decays

After computing the Feynman graphs shown in Fig. 2, we find that the analytic expression of the form factor  $\mathcal{F}_Z^{ll'}$  defined in Eq. (3.7) can be cast into the form [10]

$$\begin{aligned} \mathcal{F}_Z^{ll'} = & \sum_{i,j=1}^{n_G+n_R} B_{l'i} B_{lj}^* \left\{ \delta_{ij} \left[ -\lambda_Z \tilde{I}(\lambda_i) - 3c_W^2 L_1(\lambda_i) - s_W^2 \lambda_i I(\lambda_i) \right. \right. \\ & \left. \left. - \frac{1}{8}(1 - 2s_W^2) \lambda_i \left( 2L_1(\lambda_i) + \frac{3}{2} - \frac{3}{1-\lambda_i} - \frac{(\lambda_i+2)\lambda_i \ln \lambda_i}{(1-\lambda_i)^2} \right) \right] \right. \\ & \left. + C_{ij} \left( \frac{1}{2} L_2(\lambda_i, \lambda_j) - \frac{1}{2} \lambda_Z [K_1(\lambda_i, \lambda_j) - K_2(\lambda_i, \lambda_j) + \tilde{K}(\lambda_i, \lambda_j)] - \frac{1}{4} \lambda_i \lambda_j K_1(\lambda_i, \lambda_j) \right) \right. \\ & \left. + C_{ij}^* \sqrt{\lambda_i \lambda_j} \left( \frac{1}{2} K_1(\lambda_i, \lambda_j) + \frac{1}{4} \lambda_Z \tilde{K}(\lambda_i, \lambda_j) - \frac{1}{4} L_2(\lambda_i, \lambda_j) \right) \right\}, \end{aligned} \quad (\text{A.1})$$

where  $\lambda_i = m_i^2/M_W^2$ ,  $\lambda_Z = M_Z^2/M_W^2$ , and the definition of the loop integrals,  $I$ ,  $\tilde{I}$ ,  $L_1$ ,  $K_1$ ,  $K_2$ ,  $\tilde{K}$ , and  $L_2$ , may be found in [12]. The analytic expressions of these loop integrals have been calculated explicitly and are listed below

$$\begin{aligned} I(\lambda_i) = & \int_0^1 \int_0^1 \frac{dx dy y}{B_1(\lambda_i)} = -\frac{1}{\lambda_Z} \left[ \text{Li}_2 \left( \frac{1-\lambda_i}{1-\lambda_i-\lambda_Z \rho_+} \right) - \text{Li}_2 \left( \frac{1-\lambda_i-\lambda_Z}{1-\lambda_i-\lambda_Z \rho_+} \right) \right. \\ & \left. + \text{Li}_2 \left( \frac{1-\lambda_i}{1-\lambda_i-\lambda_Z \rho_-} \right) - \text{Li}_2 \left( \frac{1-\lambda_i-\lambda_Z}{1-\lambda_i-\lambda_Z \rho_-} \right) \right. \\ & \left. - \text{Li}_2 \left( \frac{(1-\lambda_i)^2}{(1-\lambda_i)^2 + \lambda_i \lambda_Z} \right) + \text{Li}_2 \left( \frac{(1-\lambda_i)(1-\lambda_i-\lambda_Z)}{(1-\lambda_i)^2 + \lambda_i \lambda_Z} \right) \right], \end{aligned} \quad (\text{A.2})$$

$$\begin{aligned} \tilde{I}(\lambda_i) = & \int_0^1 \int_0^1 \frac{dx dy y^2 [1-yx(1-x)]}{B_1(\lambda_i)} = \frac{1}{\lambda_Z} \left[ \frac{3}{2} - \frac{2(1-\lambda_i)}{\lambda_Z} \right. \\ & \left. + 2 \frac{\lambda_i}{\lambda_Z} \ln \lambda_i - \frac{2\lambda_i}{1-\lambda_i} \ln \lambda_i + 4 \left( \frac{1-\lambda_i}{\lambda_Z} - 1 \right) \eta \tan^{-1} \left( \frac{1}{\eta} \right) \right. \\ & \left. - \frac{2(1-\lambda_i-\lambda_Z)(1-\lambda_i) + \lambda_i \lambda_Z}{\lambda_Z} I(\lambda_i) \right], \end{aligned} \quad (\text{A.3})$$

$$\begin{aligned} L_1(\lambda_i) = & \int_0^1 \int_0^1 dx dy y \ln B_1(\lambda_i) = -\frac{3}{2} + \frac{1-\lambda_i}{\lambda_Z} + \left( 1 - \frac{2(1-\lambda_i)}{\lambda_Z} \right) \eta \tan^{-1} \left( \frac{1}{\eta} \right) \\ & - \frac{\lambda_i}{\lambda_Z} \ln \lambda_i + \frac{(1-\lambda_i)^2 + \lambda_i \lambda_Z}{\lambda_Z} I(\lambda_i), \end{aligned} \quad (\text{A.4})$$

$$K_1(\lambda_i, \lambda_j) = \int_0^1 \int_0^1 \frac{dx dy y}{B_2(\lambda_i, \lambda_j)} = -\frac{1}{\lambda_Z} \left[ \text{Li}_2 \left( \frac{1-\lambda_j}{1-\lambda_j+\lambda_Z \xi_+} \right) - \text{Li}_2 \left( \frac{1-\lambda_j+\lambda_Z}{1-\lambda_j+\lambda_Z \xi_+} \right) \right]$$

$$\begin{aligned}
& +\text{Li}_2\left(\frac{1-\lambda_j}{1-\lambda_j+\lambda_Z\xi_-}\right) - \text{Li}_2\left(\frac{1-\lambda_j+\lambda_Z}{1-\lambda_j+\lambda_Z\xi_-}\right) \\
& -\text{Li}_2\left(\frac{(1-\lambda_i)(1-\lambda_j)}{(1-\lambda_i)(1-\lambda_j)+\lambda_Z}\right) + \text{Li}_2\left(\frac{(1-\lambda_i)(1-\lambda_j+\lambda_Z)}{(1-\lambda_i)(1-\lambda_j)+\lambda_Z}\right), \quad (\text{A.5})
\end{aligned}$$

$$\begin{aligned}
K_2(\lambda_i, \lambda_j) &= \int_0^1 \int_0^1 \frac{dx dy y^2}{B_2(\lambda_i, \lambda_j)} = -\frac{1}{\lambda_Z} \left[ -1 + \frac{1}{1-\lambda_i} \ln \lambda_i \right. \\
& - \left. \left( \frac{1}{2} - \frac{\lambda_i - \lambda_j}{2\lambda_Z} \right) \ln \left( \frac{\lambda_i}{\lambda_j} \right) + \frac{\sqrt{w}}{\lambda_Z} \tan^{-1} \left( \frac{\sqrt{w}}{\lambda_i + \lambda_j - \lambda_Z} \right) \right. \\
& \left. + (1-\lambda_j)K_1(\lambda_i, \lambda_j) \right] + (\lambda_i \leftrightarrow \lambda_j), \quad (\text{A.6})
\end{aligned}$$

$$\begin{aligned}
\tilde{K}(\lambda_i, \lambda_j) &= \int_0^1 \int_0^1 \frac{dx dy y^3 x(1-x)}{B_2(\lambda_i, \lambda_j)} = -\frac{1}{\lambda_Z} \left[ \frac{1}{2} + \frac{2-\lambda_i-\lambda_j}{\lambda_Z} \right. \\
& - \frac{1}{\lambda_Z} \ln(\lambda_i \lambda_j) + \frac{(2-\lambda_i-\lambda_j+\lambda_Z)(\lambda_j-\lambda_i)}{2\lambda_Z^2} \ln \left( \frac{\lambda_i}{\lambda_j} \right) \\
& - \frac{2-\lambda_i-\lambda_j}{\lambda_Z} \frac{\sqrt{w}}{\lambda_Z} \tan^{-1} \left( \frac{\sqrt{w}}{\lambda_i + \lambda_j - \lambda_Z} \right) \\
& \left. - \left( 1 + \frac{2(1-\lambda_i)(1-\lambda_j)}{\lambda_Z} \right) K_1(\lambda_i, \lambda_j) \right], \quad (\text{A.7})
\end{aligned}$$

$$\begin{aligned}
L_2(\lambda_i, \lambda_j) &= \int_0^1 \int_0^1 dx dy y \ln B_2(\lambda_i, \lambda_j) = -\frac{3}{2} - \frac{2-\lambda_i-\lambda_j}{2\lambda_Z} + \frac{1}{2} \left( \frac{1}{2} + \frac{1}{\lambda_Z} \right) \ln(\lambda_i \lambda_j) \\
& + \frac{\lambda_i - \lambda_j}{4\lambda_Z^2} (2 + 2\lambda_Z + \lambda_i + \lambda_j) \ln \left( \frac{\lambda_i}{\lambda_j} \right) + \frac{2-\lambda_i-\lambda_j+\lambda_Z}{2\lambda_Z} \\
& \times \frac{\sqrt{w}}{\lambda_Z} \tan^{-1} \left( \frac{\sqrt{w}}{\lambda_i + \lambda_j - \lambda_Z} \right) + \frac{(1-\lambda_i)(1-\lambda_j)+\lambda_Z}{\lambda_Z} K_1(\lambda_i, \lambda_j), \quad (\text{A.8})
\end{aligned}$$

where  $\rho_{\pm} = (1 \pm i\eta)/2$  with  $\eta = \sqrt{4\lambda_Z^{-1} - 1}$ ,  $\xi_{\pm} = (\lambda_Z - \lambda_i + \lambda_j \pm i\sqrt{w})/2\lambda_Z$  with  $w = 4\lambda_i\lambda_j - (\lambda_Z - \lambda_i - \lambda_j)^2$ , and

$$B_1(\lambda_i) = (1-y)\lambda_i + y[1 - \lambda_Z y x(1-x)], \quad (\text{A.9})$$

$$B_2(\lambda_i, \lambda_j) = 1 - y + y[x\lambda_i + (1-x)\lambda_j - \lambda_Z y x(1-x)]. \quad (\text{A.10})$$

Note that  $w \geq 0$  for  $|\sqrt{\lambda_i} - \sqrt{\lambda_j}| \leq \sqrt{\lambda_Z} \leq \sqrt{\lambda_i} + \sqrt{\lambda_j}$ . If  $\sqrt{\lambda_i} + \sqrt{\lambda_j} < \sqrt{\lambda_Z}$ , then one has to analytically continue the function

$$\sqrt{w} \tan^{-1} \left( \frac{\sqrt{w}}{\lambda_i + \lambda_j - \lambda_Z} \right) = 2\sqrt{w} \tan^{-1} \left( \sqrt{\frac{\lambda_Z - (\sqrt{\lambda_i} - \sqrt{\lambda_j})^2}{(\sqrt{\lambda_i} + \sqrt{\lambda_j})^2 - \lambda_Z}} \right)$$

$$\rightarrow \sqrt{-w} \ln \left( \frac{\sqrt{1 - \frac{(\sqrt{\lambda_i} - \sqrt{\lambda_j})^2}{\lambda_Z}} + \sqrt{1 - \frac{(\sqrt{\lambda_i} + \sqrt{\lambda_j})^2}{\lambda_Z}}}{\sqrt{1 - \frac{(\sqrt{\lambda_i} - \sqrt{\lambda_j})^2}{\lambda_Z}} - \sqrt{1 - \frac{(\sqrt{\lambda_i} + \sqrt{\lambda_j})^2}{\lambda_Z}}} \right) - i\pi\sqrt{-w}. \quad (\text{A.11})$$

The dilogarithmic function  $\text{Li}_2(x)$  (with  $x$  being real) should also be continued analytically as follows:

$$\text{Li}_2(x \pm i\epsilon) = -\int_0^x dt \frac{\ln|1-t|}{t} \pm i\theta(x-1)\pi \ln x. \quad (\text{A.12})$$

For  $\sqrt{\lambda_Z} < |\sqrt{\lambda_i} - \sqrt{\lambda_j}|$ , we have checked that Eq. (A.5) and the l.h.s of Eq. (A.11) do not contain any imaginary part. This implies that  $\mathcal{F}_Z^{ll'}$  is pure dispersive in this specific kinematic range.

As we are interested in heavy neutrinos with masses larger than  $M_Z$ , the absorptive part of  $\mathcal{F}_Z^{ll'}$  will solely originate from the Fig. 2(i) in which only intermediate light neutrinos can come kinematically on-mass shell. Neglecting light neutrino masses in the calculation, we get

$$\text{Abs}(\mathcal{F}_Z^{ll'}) = i\pi \sum_{i=1}^{n_R} B_{lN_i} B_{l'N_i}^* \left[ -\frac{3}{2} - \frac{1}{\lambda_Z} + \left(1 + \frac{1}{\lambda_Z}\right)^2 \ln(1 + \lambda_Z) \right]. \quad (\text{A.13})$$

## B Loop functions of flavour-violating decays of charged leptons

In Section 4 the amplitudes of the flavour-violating decays of  $l, l \rightarrow l'l_1\bar{l}_2$  and  $l \rightarrow l'\gamma$ , are expressed in terms of all possible form factors that are derived by an explicit calculation of the Feynman graphs shown in Figs. 1–3. The photonic form factors,  $F_\gamma$  and  $G_\gamma$  in Eq. (4.1), vanish in the limit of zero external momenta and lepton masses due to the electromagnetic gauge invariance. One has consistently to expand the corresponding loop integrals up to the next order of  $q^2$  [52] in order to obtain a non-vanishing result. After a straightforward computation, we find that

$$F_\gamma(x) = \frac{7x^3 - x^2 - 12x}{12(1-x)^3} - \frac{x^4 - 10x^3 + 12x^2}{6(1-x)^4} \ln x, \quad (\text{B.1})$$

$$G_\gamma(x) = -\frac{2x^3 + 5x^2 - x}{4(1-x)^3} - \frac{3x^3}{2(1-x)^4} \ln x, \quad (\text{B.2})$$



$$F_Z(x) = -\frac{5x}{2(1-x)} - \frac{5x^2}{2(1-x)^2} \ln x, \quad (\text{B.3})$$

$$G_Z(x, y) = -\frac{1}{2(x-y)} \left[ \frac{x^2(1-y)}{1-x} \ln x - \frac{y^2(1-x)}{1-y} \ln y \right], \quad (\text{B.4})$$

$$H_Z(x, y) = \frac{\sqrt{xy}}{4(x-y)} \left[ \frac{x^2-4x}{1-x} \ln x - \frac{y^2-4y}{1-y} \ln y \right], \quad (\text{B.5})$$

$$F_{B_{ox}}(x, y) = \frac{1}{x-y} \left[ \left(1 + \frac{xy}{4}\right) \left( \frac{1}{1-x} + \frac{x^2 \ln x}{(1-x)^2} - \frac{1}{1-y} - \frac{y^2 \ln y}{(1-y)^2} \right) - 2xy \left( \frac{1}{1-x} + \frac{x \ln x}{(1-x)^2} - \frac{1}{1-y} - \frac{y \ln y}{(1-y)^2} \right) \right], \quad (\text{B.6})$$

$$G_{B_{ox}}(x, y) = -\frac{\sqrt{xy}}{x-y} \left[ (4+xy) \left( \frac{1}{1-x} + \frac{x \ln x}{(1-x)^2} - \frac{1}{1-y} - \frac{y \ln y}{(1-y)^2} \right) - 2 \left( \frac{1}{1-x} + \frac{x^2 \ln x}{(1-x)^2} - \frac{1}{1-y} - \frac{y^2 \ln y}{(1-y)^2} \right) \right]. \quad (\text{B.7})$$

Although  $F_\gamma$ ,  $G_\gamma$ ,  $F_Z$ , and  $F_{B_{ox}}$  are already known in the literature [52–54], the form factors  $G_Z$ ,  $H_Z$  and  $G_{B_{ox}}$  are newly obtained by Eqs. (B.4), (B.5) and (B.7), respectively \*.

For completeness, we list below expressions of the form factors computed at some special values of the arguments

$$F_\gamma(1) = -\frac{25}{72}, \quad F_\gamma(0) = 0; \quad (\text{B.8})$$

$$G_\gamma(1) = \frac{1}{8}, \quad G_\gamma(0) = 0; \quad (\text{B.9})$$

$$F_Z(1) = -\frac{5}{4}, \quad F_Z(0) = 0; \quad (\text{B.10})$$

$$G_Z(x, x) = -\frac{x}{2} - \frac{x \ln x}{1-x}, \quad G_Z(0, x) = -\frac{x \ln x}{2(1-x)}, \quad G_Z(1, x) = \frac{1}{2},$$

$$G_Z(0, 0) = 0, \quad G_Z(1, 0) = \frac{1}{2}, \quad G_Z(1, 1) = \frac{1}{2}; \quad (\text{B.11})$$

$$H_Z(x, x) = \frac{3}{4} - \frac{x}{4} - \frac{3}{4(1-x)} - \frac{x^3 - 2x^2 + 4x}{4(1-x)^2} \ln x,$$

---

\*Recently, we became aware of a work [55] that also arrives at similar expressions for the form factors  $G_Z$  and  $H_Z$ . Reference [55] deals with Majorana-neutrino effects in the electron and muon sector, whereas we are mainly interested here in an extensive analysis of flavour-violating  $\tau$  decays into three charged leptons.

$$H_Z(1, x) = \frac{\sqrt{x}}{4} \left[ \frac{3}{1-x} - \frac{x^2 - 4x}{(1-x)^2} \ln x \right],$$

$$H_Z(0, x) = 0, \quad H_Z(0, 0) = 0, \quad H_Z(1, 0) = 0, \quad H_Z(1, 1) = \frac{1}{8}; \quad (\text{B.12})$$

$$F_{B_{0x}}(x, x) = -\frac{x^4 - 16x^3 + 19x^2 - 4}{4(1-x)^3} - \frac{3x^3 + 4x^2 - 4x}{2(1-x)^3} \ln x,$$

$$F_{B_{0x}}(1, x) = -\frac{5x^3 - 8x^2 + 7x - 4}{8(1-x)^3} - \frac{x^3 - 4x^2}{4(1-x)^3} \ln x,$$

$$F_{B_{0x}}(0, x) = \frac{1}{1-x} + \frac{x \ln x}{(1-x)^2},$$

$$F_{B_{0x}}(0, 0) = 1, \quad F_{B_{0x}}(1, 0) = \frac{1}{2}, \quad F_{B_{0x}}(1, 1) = \frac{3}{4}; \quad (\text{B.13})$$

$$G_{B_{0x}}(x, x) = \frac{2x^4 - 4x^3 + 8x^2 - 6x}{(1-x)^3} - \frac{x^4 + x^3 + 4x}{(1-x)^3} \ln x,$$

$$G_{B_{0x}}(1, x) = -\sqrt{x} \left[ \frac{x^3 - 2x^2 + 7x - 6}{2(1-x)^3} + \frac{x^2 - 4x}{(1-x)^3} \ln x \right],$$

$$G_{B_{0x}}(0, x) = 0, \quad G_{B_{0x}}(0, 0) = 0, \quad G_{B_{0x}}(1, 0) = 0, \quad G_{B_{0x}}(1, 1) = \frac{3}{2}. \quad (\text{B.14})$$

Since all the form factors given in Eqs. (B.1)–(B.7) are multiplied by certain combinations of  $B$  and  $C$  matrices in the decay amplitudes (4.1), (4.6), (4.7) and (4.8), it will be helpful to define the following composite form factors:

$$F_\gamma^{ll'} = \sum_i B_{li}^* B_{l'i} F_\gamma(\lambda_i) = \sum_{N_i} B_{lN_i}^* B_{l'N_i} F_\gamma(\lambda_{N_i}), \quad (\text{B.15})$$

$$G_\gamma^{ll'} = \sum_i B_{li}^* B_{l'i} G_\gamma(\lambda_i) = \sum_{N_i} B_{lN_i}^* B_{l'N_i} G_\gamma(\lambda_{N_i}), \quad (\text{B.16})$$

$$F_Z^{ll'} = \sum_{ij} B_{li}^* B_{l'j} \left[ \delta_{ij} F_Z(\lambda_i) + C_{ij}^* G_Z(\lambda_i, \lambda_j) + C_{ij} H_Z(\lambda_i, \lambda_j) \right]$$

$$= \sum_{N_i N_j} B_{lN_i}^* B_{l'N_j} \left[ \delta_{N_i N_j} (F_Z(\lambda_{N_i}) + 2G_Z(0, \lambda_{N_i})) \right. \\ \left. + C_{N_i N_j}^* (G_Z(\lambda_{N_i}, \lambda_{N_j}) - G_Z(0, \lambda_{N_i}) - G_Z(0, \lambda_{N_j})) \right. \\ \left. + C_{N_i N_j} H_Z(\lambda_{N_i}, \lambda_{N_j}) \right], \quad (\text{B.17})$$

$$F_{B_{0x}}^{ll'l_1 l_2} = \sum_{ij} B_{li}^* B_{l_2 j}^* (B_{l'i} B_{l_1 j} + B_{l_1 i} B_{l'j}) F_{B_{0x}}(\lambda_i, \lambda_j) \\ + \sum_{ij} B_{li}^* B_{l_2 i}^* B_{l'j} B_{l_1 j} G_{B_{0x}}(\lambda_i, \lambda_j) \\ = \sum_{N_i N_j} \left[ (B_{lN_i}^* B_{l'N_i} \delta_{l_1 l_2} + B_{lN_i}^* B_{l_1 N_i} \delta_{l' l_2}) \delta_{N_i N_j} \left[ F_{B_{0x}}(0, \lambda_{N_i}) - F_{B_{0x}}(0, 0) \right] \right]$$

$$\begin{aligned}
& + B_{lN_i}^* B_{l_2 N_j}^* (B_{l' N_i} B_{l_1 N_j} + B_{l_1 N_i} B_{l' N_j}) \\
& \times \left[ F_{\text{Box}}(\lambda_{N_i}, \lambda_{N_j}) - F_{\text{Box}}(0, \lambda_{N_j}) - F_{\text{Box}}(0, \lambda_{N_i}) + F_{\text{Box}}(0, 0) \right] \\
& + B_{lN_i}^* B_{l_2 N_i}^* B_{l' N_j} B_{l_1 N_j} G_{\text{Box}}(\lambda_{N_i}, \lambda_{N_j}) \Big], \tag{B.18}
\end{aligned}$$

where we have made use of the identities of Eq. (2.9) in the final step of the Eqs. (B.15)–(B.18) and re-expressed all the composite form factors as a sum over the heavy neutrino states. This simplification enables us to study the behaviour of these form factors in the heavy neutrino limit.

For the purpose of illustration, we will discuss the results of this asymptotic limit in a model with two heavy Majorana neutrinos. Employing Eqs. (5.1) and (5.2) for the mixing matrices  $B$  and  $C$ , we find that for  $\lambda_{N_1} = m_{N_1}^2/M_W^2 \gg 1$  and  $\rho = m_{N_2}^2/m_{N_1}^2 \gg 1$ ,

$$F_\gamma^{ll'} \rightarrow -\frac{1}{6} s_L^{\nu_i} s_L^{\nu_{i'}} \ln \lambda_{N_1}, \tag{B.19}$$

$$G_\gamma^{ll'} \rightarrow \frac{1}{2} s_L^{\nu_i} s_L^{\nu_{i'}}, \tag{B.20}$$

$$\begin{aligned}
F_Z^{ll'} & \rightarrow -\frac{3}{2} s_L^{\nu_i} s_L^{\nu_{i'}} \ln \lambda_{N_1} \\
& + s_L^{\nu_i} s_L^{\nu_{i'}} \sum_{i=1}^{\text{ng}} (s_L^{\nu_i})^2 \frac{\lambda_{N_1}}{(1+\rho^{\frac{1}{2}})^2} \left( -\frac{3}{2}\rho + \frac{-\rho + 4\rho^{\frac{3}{2}} - \rho^2}{4(1-\rho)} \ln \rho \right), \tag{B.21}
\end{aligned}$$

$$\begin{aligned}
F_{\text{Box}}^{ll'l_1 l_2} & \rightarrow - (s_L^{\nu_i} s_L^{\nu_{i'}} \delta_{l_1 l_2} + s_L^{\nu_i} s_L^{\nu_{i_1}} \delta_{l' l_2}) \\
& + s_L^{\nu_i} s_L^{\nu_{i'}} s_L^{\nu_{i_1}} s_L^{\nu_{i_2}} \frac{\lambda_{N_1}}{(1+\rho^{\frac{1}{2}})^2} \left( -\rho - \frac{\rho + \rho^{\frac{3}{2}} + \rho^2}{1-\rho} \ln \rho \right). \tag{B.22}
\end{aligned}$$

In the limit  $\rho \rightarrow 1$  and for  $\lambda_{N_1} \gg 1$ , Eqs. (B.21) and (B.22) take the form

$$F_Z^{ll'} \rightarrow -\frac{3}{2} s_L^{\nu_i} s_L^{\nu_{i'}} \ln \lambda_{N_1} - \frac{1}{2} s_L^{\nu_i} s_L^{\nu_{i'}} \sum_{i=1}^{\text{ng}} (s_L^{\nu_i})^2 \lambda_{N_1}, \tag{B.23}$$

$$F_{\text{Box}}^{ll'l_1 l_2} \rightarrow - (s_L^{\nu_i} s_L^{\nu_{i'}} \delta_{l_1 l_2} + s_L^{\nu_i} s_L^{\nu_{i_1}} \delta_{l' l_2}) + \frac{1}{2} s_L^{\nu_i} s_L^{\nu_{i'}} s_L^{\nu_{i_1}} s_L^{\nu_{i_2}} \lambda_{N_1}. \tag{B.24}$$

From Eqs. (B.19)–(B.24), it is obvious that all the composite form factors,  $F_\gamma^{ll'}$ ,  $G_\gamma^{ll'}$ ,  $F_Z^{ll'}$ , and  $F_{\text{Box}}^{ll'l_1 l_2}$ , violate the decoupling theorem [27]. Such a violation is a common feature for all theories based on the spontaneous symmetry breaking mechanism. We emphasize again the fact that terms of  $\mathcal{O}((s_L^{\nu_i})^2)$  in  $F_Z^{ll'}$  increase logarithmically with the heavy neutrino mass,  $m_{N_1}$ , while terms proportional to  $(s_L^{\nu_i})^4$  in Eqs. (B.23) and (B.24) show a strong quadratic dependence in  $m_{N_1}$  and should not be neglected for  $m_{N_1} > 200$  GeV [29].

## C Three-body phase-space integrals

As we have seen from Eq. (4.6), the  $\gamma$ -mediated amplitude of the decay  $l(p) \rightarrow l'(p')l_1(p_1)\bar{l}_2(p_2)$  contains a non-local interaction which leads to an infra-red singularity in the limit  $q^2 \equiv (p_1 + p_2)^2 \rightarrow 0$ . This divergency can only be avoided if one assumes that the leptons,  $l_1$  and  $l_2$ , coupled to the virtual photon are not strictly massless, *i.e.*  $m_{l_1} = m_{l_2} = \varepsilon \neq 0$ . Thus, after performing phase-space integration, we neglect all those terms that vanish as  $\varepsilon \rightarrow 0$ . On the other hand, the mass of  $l'$  can safely be set to zero. Then, the phase-space boundaries can be given by

$$4\varepsilon^2 \leq s_2 \leq m^2, \quad s_1^\pm = \frac{1}{2}(m^2 - s_2) \left[ 1 \pm \sqrt{1 - \frac{4\varepsilon^2}{s_2}} \right] + \varepsilon^2, \quad (\text{C.1})$$

where  $s_1 = (p' + p_2)^2$ ,  $s_2 = (p_1 + p_2)^2$ ,  $m$  is the mass of the decaying lepton  $l$ , and  $s_1^{+(-)}$  is the upper (lower) limit of the Mandelstam variable  $s_1$ .

The divergent phase-space integrals relevant for the decay  $l \rightarrow l'l_1\bar{l}_2$  (with  $l' \neq l_2$ ) are given by the following expressions:

$$P_1 = \int \int ds_2 ds_1 \frac{1}{s_2} = m^2 \left( \ln \frac{m^2}{\varepsilon^2} - 3 \right) + \mathcal{O}(\varepsilon), \quad (\text{C.2})$$

$$P_2 = \int \int ds_2 ds_1 \frac{s_1}{s_2} = m^4 \left( \frac{1}{2} \ln \frac{m^2}{\varepsilon^2} - \frac{7}{4} \right) + \mathcal{O}(\varepsilon), \quad (\text{C.3})$$

$$P_3 = \int \int ds_2 ds_1 \frac{s_1^2}{s_2} = m^6 \left( \frac{1}{3} \ln \frac{m^2}{\varepsilon^2} - \frac{4}{3} \right) + \mathcal{O}(\varepsilon). \quad (\text{C.4})$$

Note that a different result would have been obtained in Eqs. (C.2)–(C.4) if we had originally expanded the square root existing in  $s_1^\pm$  in terms of  $\varepsilon$  and then performed the phase-space integration. Apparently, this technical problem seems to have caused some confusion in the literature, as far as the correct analytic expression of the non-local interaction in Eqs. (4.9) and (4.10) is concerned. In the three-body leptonic decays of  $l$  where  $l' = l_1 = l_2$ , one may have to take into account an additional divergent phase space integral when interfering the two possible,  $s_1$ -channel and  $s_2$ -channel,  $\gamma$ -exchange amplitudes, *i.e.*

$$P_4 = \int \int ds_2 ds_1 \frac{1}{s_2 s_1} = -\frac{\pi^2}{12} - \ln^2 2 + \frac{1}{2} \ln^2 \frac{m^2}{\varepsilon^2} + \mathcal{O}(\varepsilon). \quad (\text{C.5})$$

The integral  $P_4$  in Eq. (C.5), however, is always multiplied by the small mass  $\varepsilon$  of the final leptons and therefore goes to zero as  $\varepsilon \rightarrow 0$ . As a result, the only type of divergency for  $\varepsilon \rightarrow 0$  that appears in Eqs. (4.9) and (4.10) is the logarithmic one,  $\ln(m^2/\varepsilon^2)$ .

## References

- [1] For reviews see, *e.g.*, P. Langacker, *Phys. Rep.* **C72** (1981) 185; R.N. Mohapatra, *Unification and Supersymmetry* (Springer-Verlag, New York, 1986).
- [2] E. Witten, *Nucl. Phys.* **B268** (1986) 79; R.N. Mohapatra and J.W.F. Valle, *Phys. Rev.* **D34** (1986) 1642; J.L. Hewett and T.G. Rizzo, *Phys. Rep.* **183** (1989) 193.
- [3] T. Yanagida, Proceedings of the *Workshop on Unified Theory and Baryon Number of the Universe*, eds. O. Swada and A. Sugamoto (KEK, 1979) p. 95; M. Gell-Mann, P. Ramond, and R. Slansky, *Supergravity*, eds. P. van Nieuwenhuizen and D. Friedman (North-Holland, Amsterdam, 1979) p. 315.
- [4] H. Georgi and C. Jarlskog, *Phys. Lett.* **B86** (1979) 297.
- [5] A. Pilaftsis, *Z. Phys.* **C55** (1992) 275.
- [6] F. del Aguila, E. Laermann, and P.M. Zerwas, *Nucl. Phys.* **B297** (1988) 1; J. Maalampi, K. Mursula, and R. Vuopionperä, *Nucl. Phys.* **B372** (1992) 23; C.A. Heusch and P. Minkowski, *Nucl. Phys.* **B416** (1994) 3.
- [7] W. Buchmüller and C. Greub, *Nucl. Phys.* **B363** (1991) 345.
- [8] D.A. Dicus and P. Roy, *Phys. Rev.* **D44** (1991) 1593; A. Datta and A. Pilaftsis, *Phys. Lett.* **B278** (1992) 162; A. Pilaftsis [5]; D. Choudhury, R.M. Godbole, and P. Roy, *Phys. Lett.* **B308** (1993) 394.
- [9] For a complete background analysis of a possible production of heavy Majorana neutrinos at hadron colliders, see, *e.g.*, A. Datta, M. Guchait, and A. Pilaftsis, RAL preprint (1993), RAL-93-074, *Phys. Rev. D* (to appear).
- [10] J.G. Körner, A. Pilaftsis, and K. Schilcher, *Phys. Lett.* **B300** (1993) 381.
- [11] A. Pilaftsis, *Phys. Lett.* **B285** (1992) 68; J.G. Körner, A. Pilaftsis, and K. Schilcher, *Phys. Rev.* **D47** (1993) 1080.
- [12] J. Bernabéu, J.G. Körner, A. Pilaftsis, and K. Schilcher, *Phys. Rev. Lett.* **71** (1993) 2695.

- [13] S. Bertolini and A. Sirlin, *Phys. Lett.* **B257** (1991) 179; E. Gates and J. Terning, *Phys. Rev. Lett.* **67** (1991) 1840.
- [14] B.A. Kniehl and H.-G. Kohrs, *Phys. Rev.* **D48** (1993) 225.
- [15] M.E. Peskin and T. Takeuchi, *Phys. Rev. Lett.* **65** (1990) 964; *Phys. Rev.* **D46** (1992) 381; G. Altarelli and R. Barbieri, *Phys. Lett.* **B253** (1991) 161; G. Altarelli, R. Barbieri, and S. Jadach, *Nucl. Phys.* **B369** (1992) 3.
- [16] I. Maksymyk, C.P. Burgess, and D. London, McGill preprint 1993, MCGILL-93-13.
- [17] A. Ilakovac, B.A. Kniehl, and A. Pilaftsis, *Phys. Lett.* **B317** (1993) 609; by accident, also *Phys. Lett.* **B320** (1994) 329.
- [18] B.A. Kniehl and A. Pilaftsis, DESY preprint 1994, DESY/94-020.
- [19] P. Langacker and D. London, *Phys. Rev.* **D38** (1988) 886; G. Bhattacharyya *et al.*, *Mod. Phys. Lett.* **A6** (1991) 2921; E. Nardi, E. Roulet, and D. Tommasini, *Nucl. Phys.* **B386** (1992) 239; *Phys. Rev.* **D46** (1992) 3040; C.P. Burgess, S. Godfrey, H. König, D. London, and I. Maksymyk, McGill preprint 1993, MCGILL-93/12 (hep-ph/9312291).
- [20] See, *e.g.*, W. Buchmüller, C. Greub, and H.-G. Kohrs, *Nucl. Phys.* **B370** (1992) 3.
- [21] S. Kelley, J.L. Lopez, D.V. Nanopoulos, and H. Pois, *Nucl. Phys.* **B358** (1991) 27; R. Arnowitt and P. Nath, *Phys. Rev. Lett.* **66** (1991) 2708.
- [22] D. Wyler and L. Wolfenstein, *Nucl. Phys.* **B218** (1983) 205.
- [23] J. Bernabéu, A. Santamaria, J. Vidal, A. Mendez, and J.W.F. Valle, *Phys. Lett.* **B187** (1987) 303.
- [24] N. Rius and J.W.F. Valle, *Phys. Lett.* **B246** (1990) 249;
- [25] For example, see, M. Nowakowski and A. Pilaftsis, *Phys. Rev.* **D48** (1993) 259.
- [26] M.C. Gonzalez-Garcia, A. Santamaria, and J.W.F. Valle, *Nucl. Phys.* **B342** (1990) 108;
- [27] T. Appelquist and J. Carazzone, *Phys. Rev.* **D11** (1975) 2856.

- [28] See, *e.g.*, H. Fritzsch, *Phys. Lett.* **B70** (1977) 436; *Phys. Lett.* **B73** (1978) 317; Z.G. Berezhiani, *Phys. Lett.* **B129** (1983) 99; G.K. Leontaris and J.D. Vergados, *Phys. Lett.* **B258** (1991) 111; P. Ramond, R.G. Roberts, and G.G. Ross, *Nucl. Phys.* **B406** (1993) 19.
- [29] M.C. Gonzalez-Garcia and J.W.F. Valle, *Mod. Phys. Lett.* **A7** (1992) 477; J.W.F. Valle, Valencia preprint 1993, FTUV/93-52.
- [30] J.C. Pati and A. Salam, *Phys. Rev.* **D10** (1974) 275.
- [31] R.N. Mohapatra and G. Senjanovic, *Phys. Rev.* **D23** (1981) 165.
- [32] X.-G. He, G.C. Joshi, H. Lew, and R.R. Volkas, *Phys. Rev.* **D43** (1991) R22; R. Foot, X.-G. He, H. Lew, and R.R. Volkas, Oregon preprint 1993, OITS-532.
- [33] Y. Chikashige, R.N. Mohapatra, and R.D. Peccei, *Phys. Lett.* **B98** (1981) 265.
- [34] G. Gelmini and M. Roncadelli, *Phys. Lett.* **B99** (1981) 411.
- [35] E. Akhmedov, Z. Berezhiani, R. Mohapatra, and G. Senjanovic, *Phys. Lett.* **B299** (1993) 90; R.N. Mohapatra and X. Zhang, *Phys. Lett.* **B305** (1993) 106.
- [36] A. Pilaftsis, *Phys. Rev.* **D49** (1994) 2398.
- [37] M. Fukugita and T. Yanagida, *Phys. Lett.* **B174** (1986) 45; *Phys. Rev.* **D42** (1990) 1285.
- [38] V.A. Kuzmin, V.A. Rubakov, and M.E. Shaposhnikov, *Phys. Lett.* **B155** (1985) 36.
- [39] For recent reviews see, *e.g.*, A.D. Dolgov, *Phys. Rep.* **222** (1992) 309; A.G. Cohen, D.B. Kaplan, and A.E. Nelson, *Ann. Rev. Nucl. Part. Phys.* **43** (1993) 27.
- [40] M.A. Luty, *Phys. Rev.* **D45** (1992) 455; C.E. Vayonakis, *Phys. Lett.* **B286** (1992) 92; K. Enqvist and I. Vilja, *Phys. Lett.* **B299** (1993) 281.
- [41] W. Buchmüller and T. Yanagida, *Phys. Lett.* **B302** (1993) 240.
- [42] B.A. Campbell, S. Davidson, J. Ellis, and K.A. Olive, *Phys. Lett.* **B297** (1992) 118.

- [43] H. Dreiner and G.G. Ross, *Nucl. Phys.* **B410** (1993) 188; S.A. Abel and K.E.C. Benson, RAL preprint (1993), RAL-93-103.
- [44] J.M. Cline, K. Kainulainen, and K.A. Olive, *Phys. Rev. Lett.* **71** (1993) 2372.
- [45] V. Barger, M.S. Berger, P. Ohmann, and R.J.N. Phillips, Madison preprint in 1993, MAD-PH-781, presented at Workshop on Physics at Current Accelerators and the Supercollider, Argonne, IL, 2-5 June 1993.
- [46] G.G. Ross and R.G. Roberts, *Nucl. Phys.* **B377** (1992) 571; R.G. Roberts and L. Roszkowski, *Phys. Lett.* **B309** (1993) 329.
- [47] G. Eilam and T.G. Rizzo, *Phys. Lett.* **B188** (1987) 91; M.J.S. Levine, *Phys. Rev.* **D36** (1987) 1329; J. Bernabéu and A. Santamaria, *Phys. Lett.* **B197** (1987) 418; F. Gabbiani, J.H. Kim, and A. Masiero, *Phys. Lett.* **B214** (1988) 398; D. Choudhuri, A.S. Joshipura, and S.D. Rindani, *Phys. Rev. Lett.* **67** (1991) 548; R.N. Mohapatra, S. Nussinov, and X. Zhang, Maryland preprint 1993, UMDHEP 94-30; T.S. Kosmas, G.K. Leontaris, and J.D. Vergados, Ioannina preprint 1993, IOA.309/93
- [48] See, *e.g.*, T.P. Cheng and L.-F. Li, *Phys. Rev.* **D44** (1991) 1502.
- [49] Particle Data Group, K. Hikasa et al., Review of particle properties, *Phys. Rev.* **D45** (1992) S1.
- [50] See, *e.g.*, M.A.B. Bég and A. Sirlin, *Phys. Rep.* **88** (1982) 1.
- [51] T.P. Cheng and L.-F. Li, *Phys. Rev. Lett.* **45** (1980) 1908.
- [52] T. Inami and C.S. Lim, *Prog. Theor. Phys.* **65** (1981) 297; 1772 (Errata).
- [53] E. Ma and A. Pramudita, *Phys. Rev.* **D22** (1980) 214.
- [54] M. Gronau, C. Leung, and J. Rosner, *Phys. Rev.* **D29** (1984) 2539.
- [55] L.N. Chang, D. Ng, and J.N. Ng, TRIUMF preprint 1994, TRI-PP-94-01.



## Figure Captions

- Fig. 1:** Feynman graphs responsible for generating the effective vertex  $\gamma ll'$  ( $l \neq l'$ ).
- Fig. 2:** Feynman graphs responsible for generating the effective vertex  $Z ll'$  ( $l \neq l'$ ).
- Fig. 3:** Feynman diagrams relevant for the leptonic decays  $l \rightarrow l' l_1 \bar{l}_2$ .
- Fig. 4:**  $B(\tau^- \rightarrow e^- e^- e^+)$  (solid line) and  $B(\tau^- \rightarrow e^- \mu^- \mu^+)$  (dashed line) as a function of the heavy neutrino mass  $m_N (= m_{N_1} = m_{N_2})$  assuming  $(s_L^{\nu_r})^2 = 0.07$ ,  $(s_L^{\nu_e})^2 = 0.015$  and  $(s_L^{\nu_\mu})^2 \simeq 0$ . Numerical results obtained when seemingly suppressed terms of  $\mathcal{O}((s_L^{\nu_i})^4)$  are neglected, are also presented for  $B(\tau^- \rightarrow e^- e^- e^+)$  (dotted line) and  $B(\tau^- \rightarrow e^- \mu^- \mu^+)$  (dash-dotted line).
- Fig. 5:**  $B(\tau^- \rightarrow e^- e^- e^+)$  (solid line) and  $B(\tau^- \rightarrow e^- \mu^- \mu^+)$  (dashed line) as a function of the heavy neutrino mass  $m_N (= m_{N_1} = m_{N_2})$  using  $(s_L^{\nu_r})^2 = 0.035$ ,  $(s_L^{\nu_e})^2 = 0.010$  and  $(s_L^{\nu_\mu})^2 \simeq 0$ . We also display numerical results obtained by neglecting seemingly suppressed terms of  $\mathcal{O}((s_L^{\nu_i})^4)$  in the calculation of  $B(\tau^- \rightarrow e^- e^- e^+)$  (dotted line) and  $B(\tau^- \rightarrow e^- \mu^- \mu^+)$  (dash-dotted line).
- Fig. 6:**  $B(\tau^- \rightarrow e^- e^- e^+)$  as a function of the ratio of the two heavy Majorana neutrinos  $m_{N_2}/m_{N_1}$  for  $m_{N_1} = 200$  GeV (solid line) and 500 GeV (dashed line). We have assumed  $(s_L^{\nu_r})^2 = 0.07$ ,  $(s_L^{\nu_e})^2 = 0.015$  and  $(s_L^{\nu_\mu})^2 \simeq 0$ . The corresponding numerical results for  $B(\tau^- \rightarrow e^- \mu^- \mu^+)$  are shown for  $m_{N_1} = 200$  GeV (dotted line) and 500 GeV (dash-dotted line).
- Fig. 7:** Numerical estimates of  $B(Z \rightarrow e^- \tau^+) + B(Z \rightarrow e^+ \tau^-)$  as a function of the heavy neutrino mass  $m_N (= m_{N_1} = m_{N_2})$  for three representative values of the mixing parameters  $(s_L^{\nu_r})^2$  and  $(s_L^{\nu_e})^2$  ( $(s_L^{\nu_\mu})^2 = 0$ ): (i)  $(s_L^{\nu_r})^2 = 0.070$  and  $(s_L^{\nu_e})^2 = 0.015$  (solid line), (ii)  $(s_L^{\nu_r})^2 = 0.035$  and  $(s_L^{\nu_e})^2 = 0.010$  (dashed line), and (iii)  $(s_L^{\nu_r})^2 = 0.020$  and  $(s_L^{\nu_e})^2 = 0.010$  (dotted line).
- Fig. 8:** Numerical estimates of  $B(Z \rightarrow e^- \tau^+) + B(Z \rightarrow e^+ \tau^-)$  versus the ratio of the two heavy Majorana neutrinos  $m_{N_2}/m_{N_1}$  for selected values of  $m_{N_1} = 200$  GeV (solid line), 400 GeV (dashed line), 600 GeV (dotted line), and 1 TeV (dash-dotted line). We have used  $(s_L^{\nu_r})^2 = 0.07$  and  $(s_L^{\nu_e})^2 = 0.015$ .

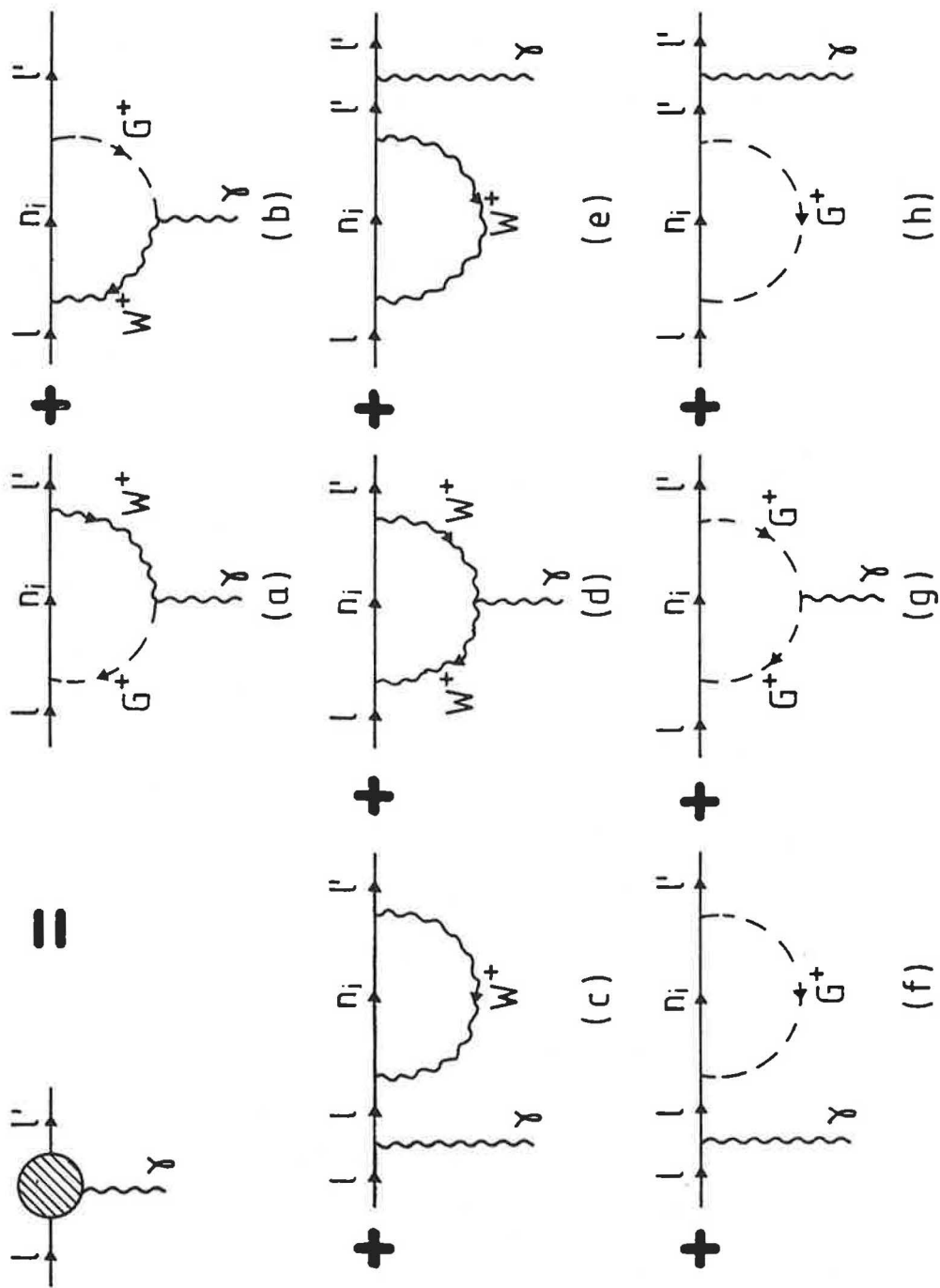

Fig. 1

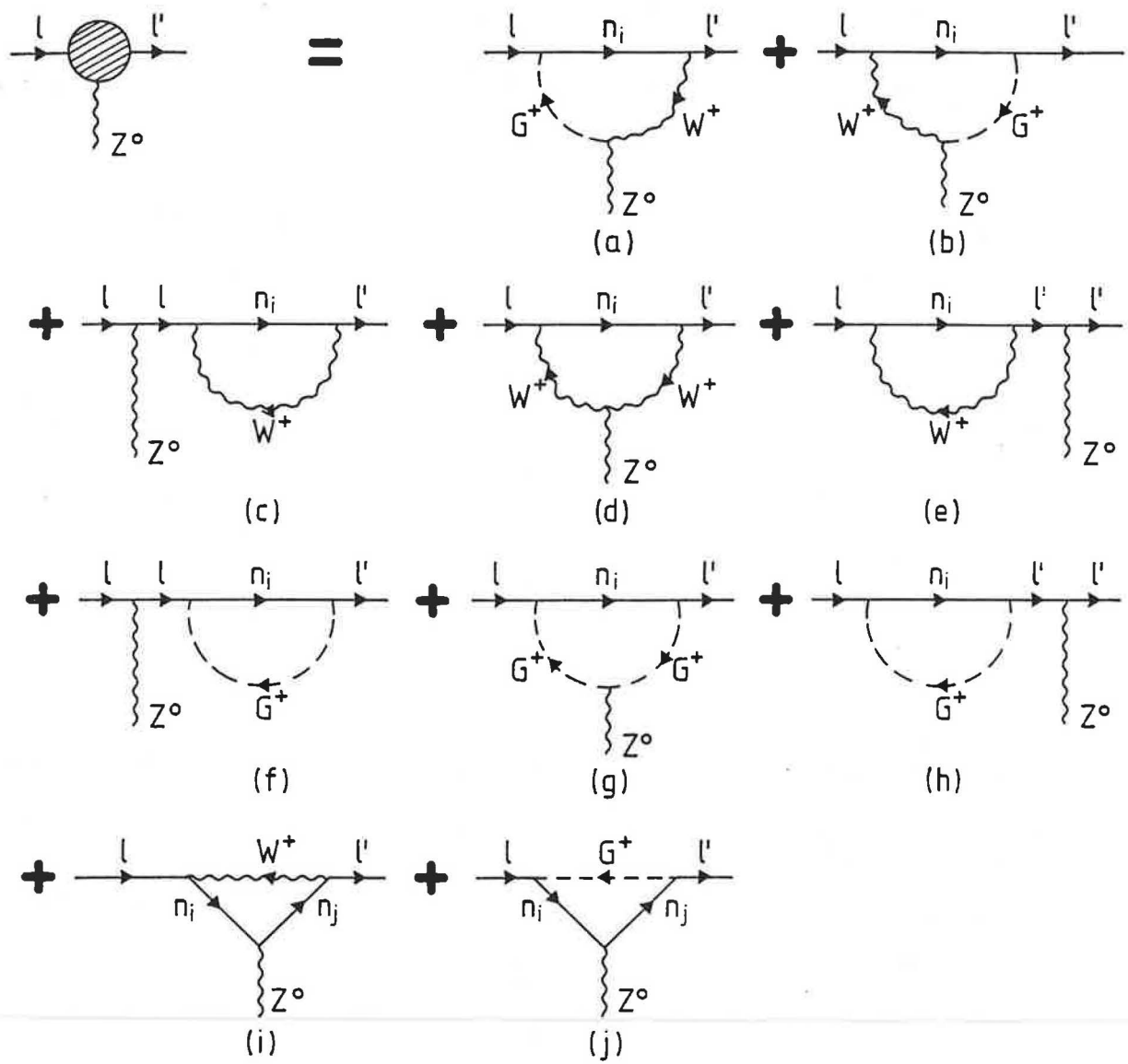
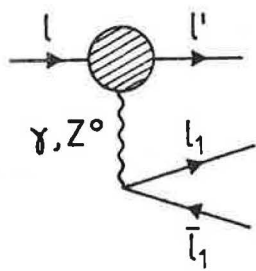
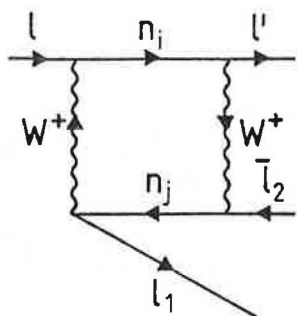

Fig. 2



(a)



(b)

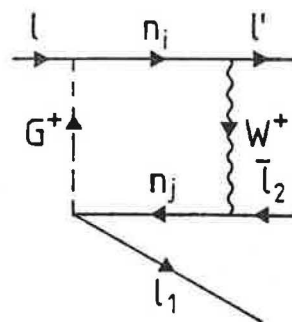

(c)

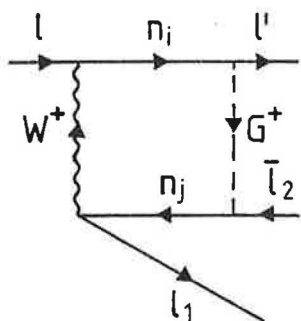

(d)

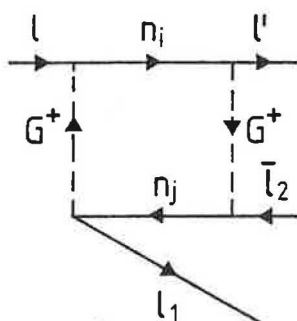

(e)

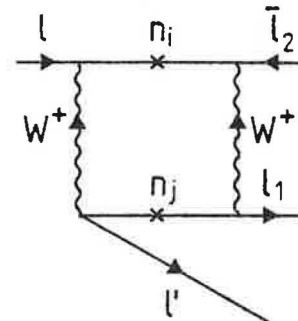

(f)

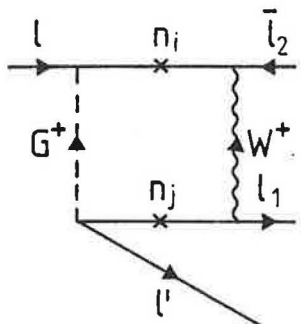

(g)

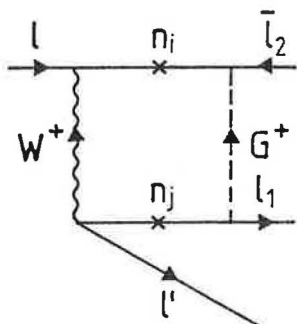

(h)

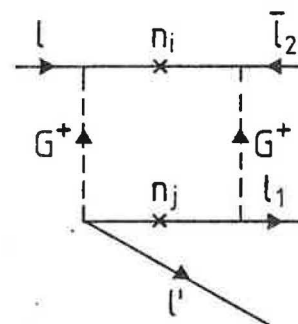

(i)

**+** ( $l_1 \leftrightarrow l'$ )

Fig. 3

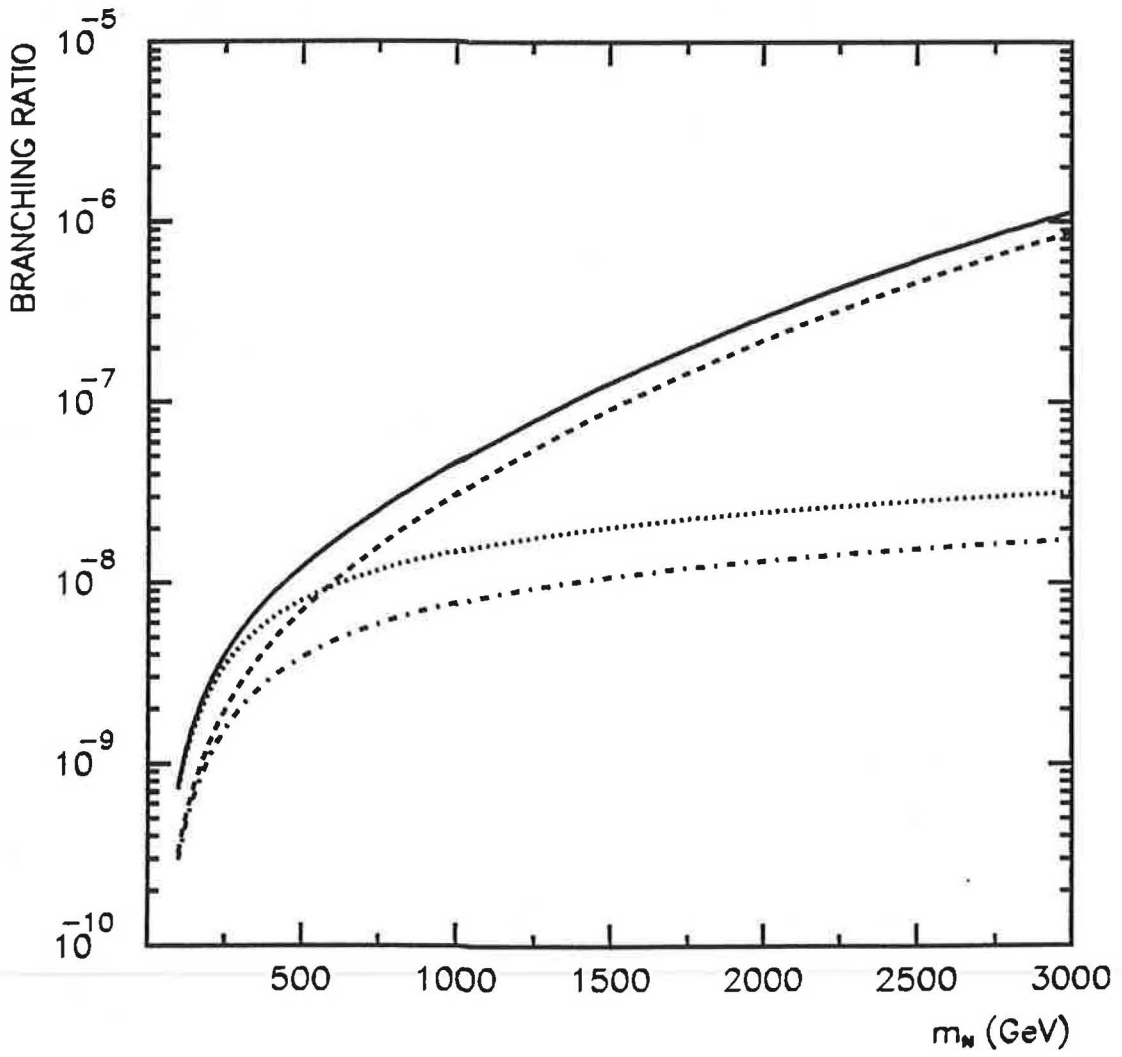

Fig. 4

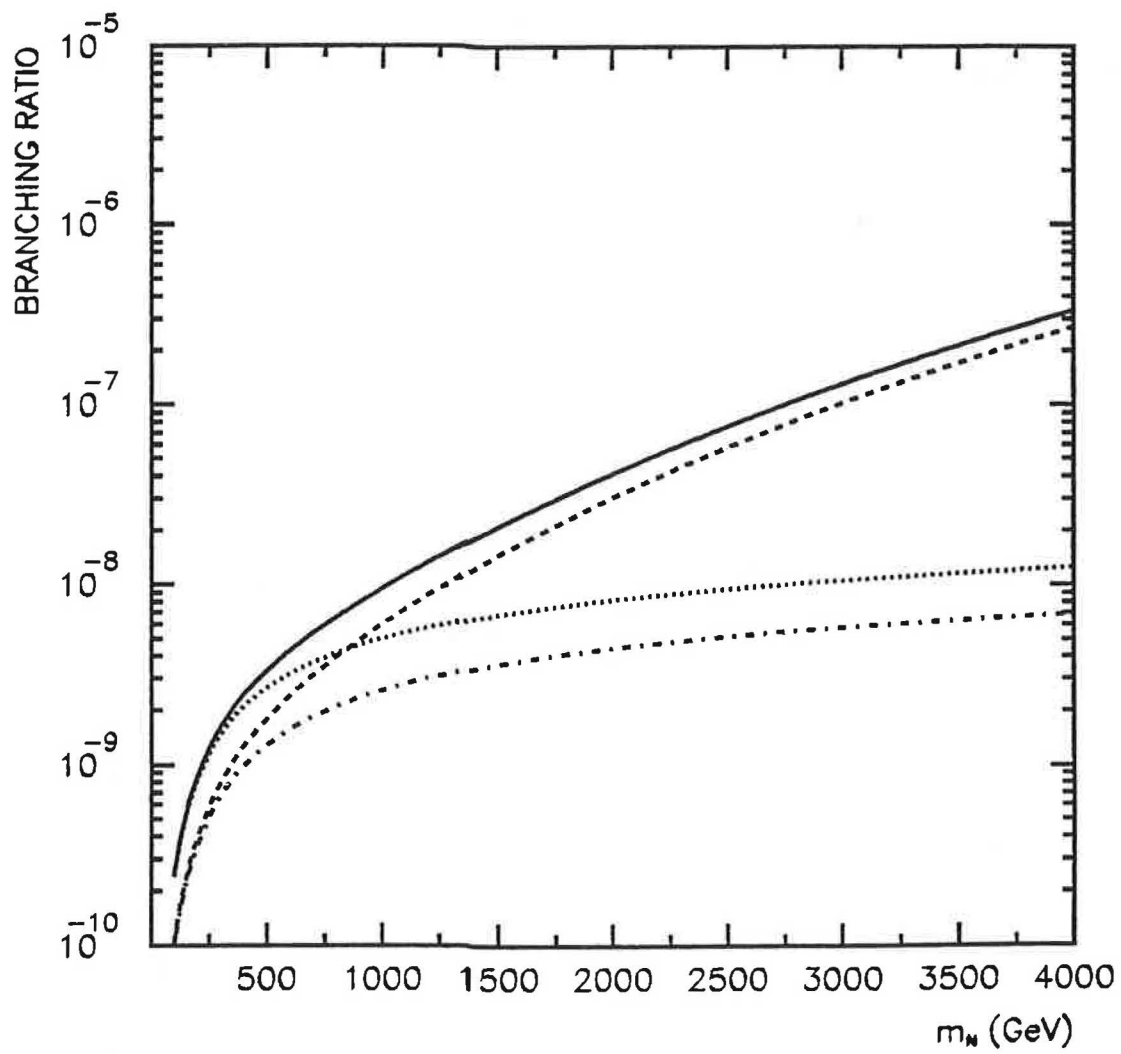

Fig. 5

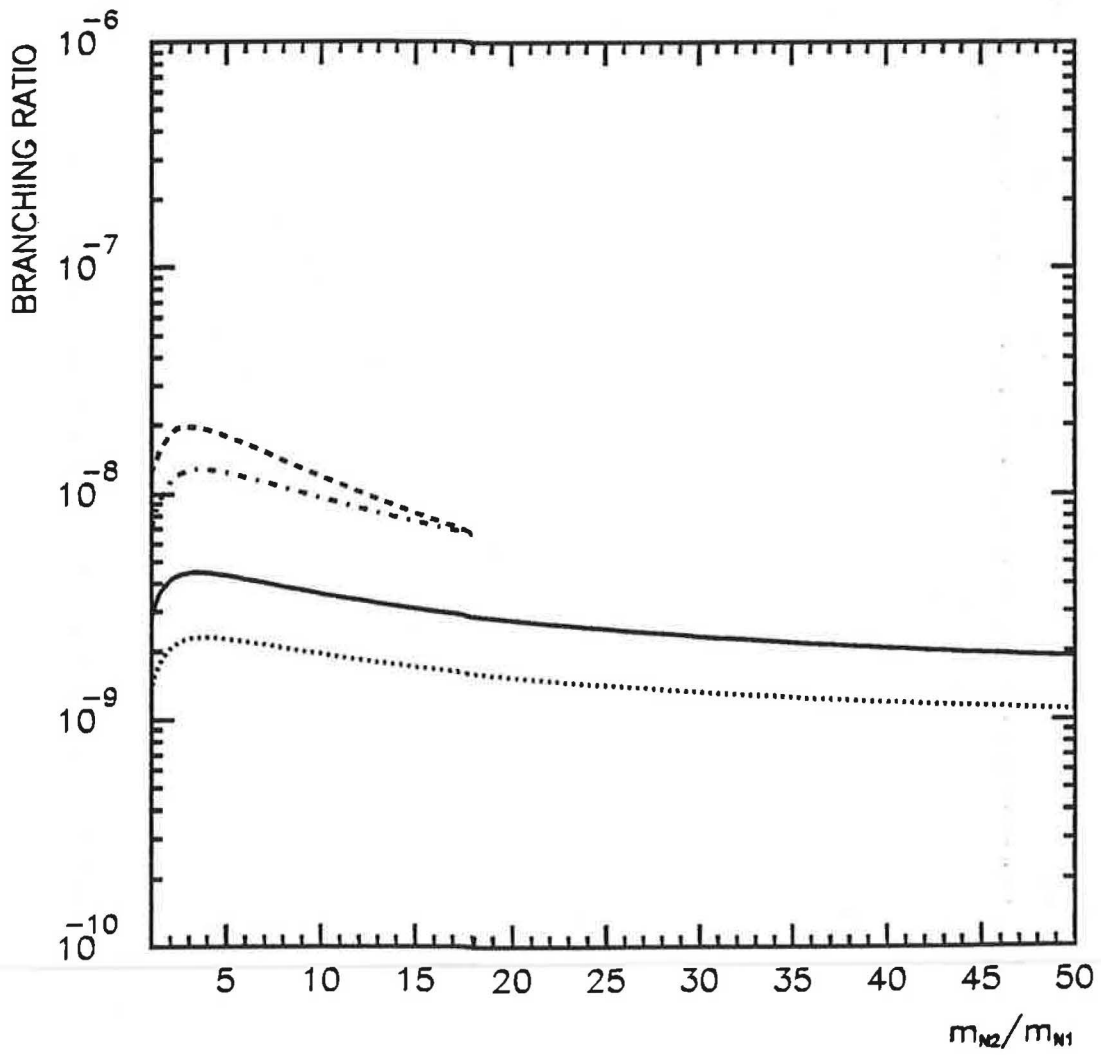

Fig. 6

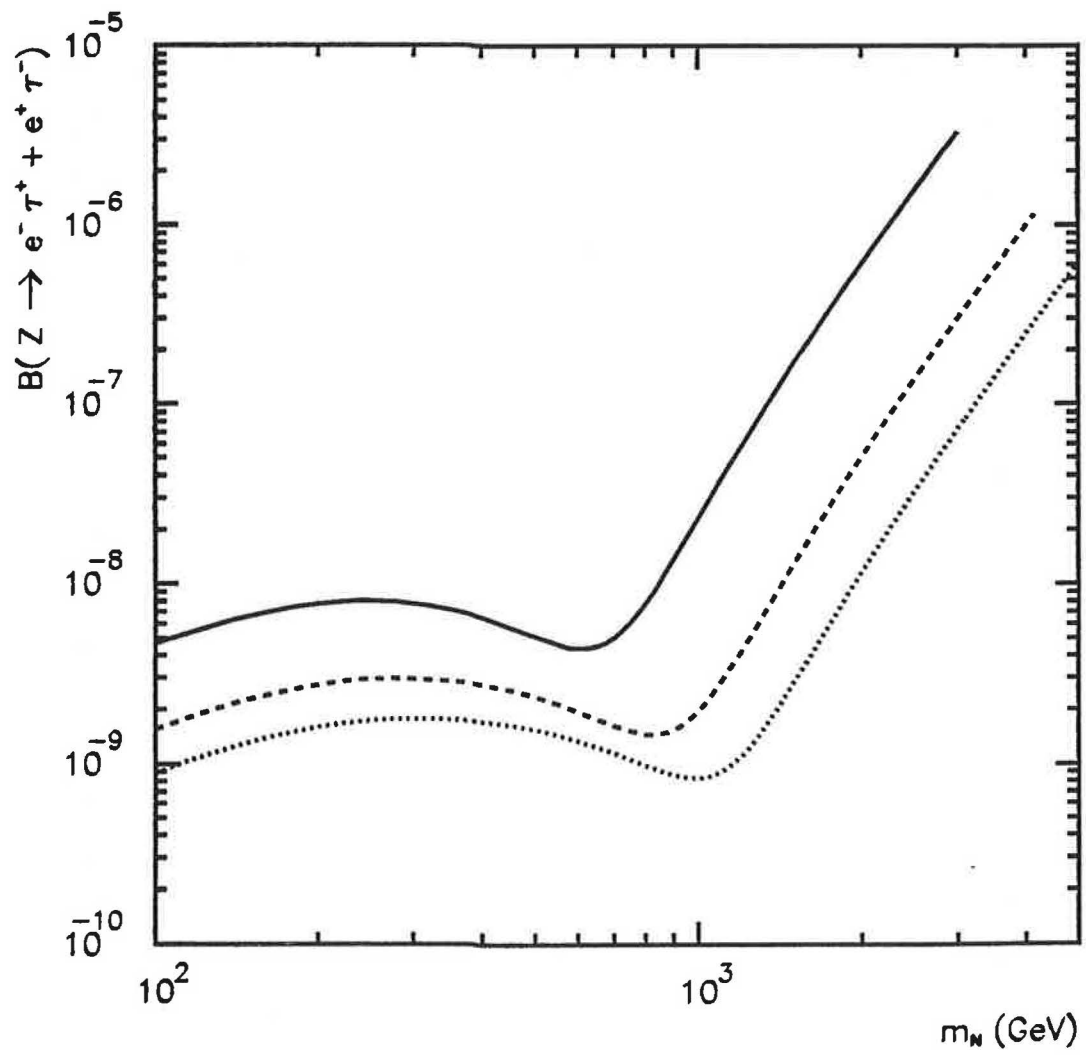

Fig. 7



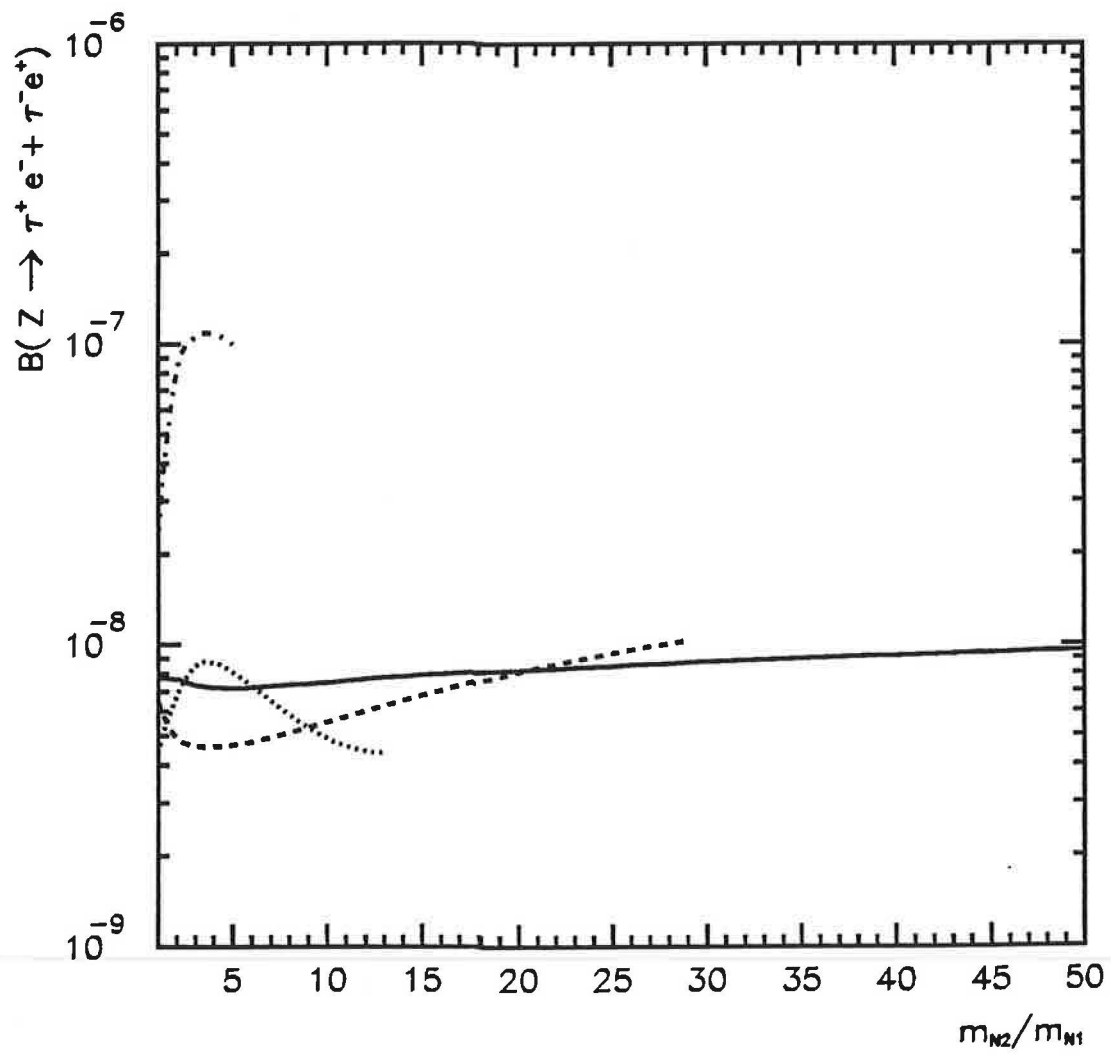

Fig. 8





